



University of
**Central
Florida**

Senior Design Project

Essence of Music

Submitted To:

Dr. Lei Wei

EEL 4915 - Summer 2016

Senior Design 2

Submitted by:

Group 14

Joshua Garber

Baron Dolletski-Lazar

Nelson Tan

Orlando, FL

Table of Contents

1.0 Executive Summary	1
2.0 Requirements Specifications	2
2.1 Software Requirements	3
2.2 Power System Requirements	3
2.3 Sound Playback Requirements	5
2.4 Hardware Specifications	6
2.5 Design Constraints	6
3.0 Research and Background	7
3.1 Similar Projects	7
3.1.1 Sound Playback Projects	8
3.1.2 LED Display Projects	8
3.1.3 Wireless Control Projects	10
3.2 Speaker Construction and Design	11
3.3 Power Systems	13
3.4 Wireless Applications	18
3.4.1 Phone Application	18
3.4.2 Web Application	19
3.4.3 Decision	20
3.5 LEDs and Display	20
3.5.1 Miniature LEDs	21
3.5.2 High Power LEDs	21
3.5.3 RGB LEDs	21
3.5.4 Flashing LEDs	22
3.5.5 Digital LEDs	23
3.5.6 Decision	24
3.6 Microcontrollers	24
3.7 Communication Methodology	28
3.7.1 Wi-Fi	28
3.7.2 Bluetooth	30
3.7.3 Hardwiring	33
3.7.4 Decision	33
4.0 Project Design	35

4.1 Hardware Design	36
4.1.1 Power System	38
4.1.2 Speaker Systems	41
4.1.3 Microcontroller Layout and LED System	42
4.1.4 Input Signal Systems	43
4.1.4.1 Wireless Input	45
4.1.4.2 Wired Input	46
4.1.5 PCB Design	46
4.1.6 Casing Design	48
4.2 Software Design	49
4.2.1 Programming Language	49
4.2.2 Control Methodology	49
4.2.3 Application Design	50
4.2.3.1 User Interface	50
4.2.3.2 Software Diagrams	53
5.0 Design Constraints	57
5.1 Economic and Time Constraints	57
5.2 Manufacturability and Sustainability Constraints	58
5.2.1 Expected Lifetime and Durability	58
5.2.2 Transportability	59
5.3 Health and Safety Constraints	60
5.3.1 Sound Levels	60
5.3.2 Brightness Settings	61
5.4 Hardware Constraints	61
6.0 Prototype Construction	62
6.1 Hardware Construction	62
6.1.1 Power Unit Construction	63
6.1.2 Speaker Construction	65
6.1.3 Bluetooth Construction	65
6.1.4 PCB and LED Construction	65
6.1.5 Case Frame	66
6.2 Software Development	66
6.2.1 Android Coding	66
6.2.2 Microcontroller Coding	66

7.0 Prototype Testing	67
7.1 Hardware	67
7.1.1 Power System	67
7.1.2 Speaker System	68
7.1.2.1 Decibel Levels	69
7.1.2.2 Sound Clarity	70
7.1.3 LED Array System	71
7.1.3.1 Metadata Display	71
7.1.3.2 Lightshow Patterns	71
7.1.3.3 User Customizability	72
7.2 Software	72
7.2.1 Exhaustive Pattern Testing	73
8.0 Administrative Content	74
8.1 Budget and Finance	74
8.2 Milestones and Deadlines	75
8.3 Group Organization	76
9.0 Project Summary and Conclusions	77
Appendices	78
Appendix A - Copyright Permissions	
Appendix B - References	
Appendix C - Code	

1.0 Executive Summary

Everyone enjoys listening to music and adding a light and audio show to the room. Often time people listen to music while being productive or for enjoyment, and Essence of Music adds to that audio experience with an enjoyable light display in order to create a calmer and relaxing environment. That being said, wireless operation and ease-of-use are essential aspects to useful projects that are created in today's electronics; one important motivation for Essence of Music is the desire to practice sending and receiving data wirelessly through Wi-Fi and/ or Bluetooth. From a design perspective, this will challenge and teach the Essence of Music team how to apply filters to music signals while also helping realize how to apply devices such as 802.11 Wi-Fi capability in order for ease-of-use for the device's user. Music is something that the group is passionate about and adding a visual component sounds both enjoyable and compelling to create.

The main objective of Essence of Music is to lighten up the mood in an office or get-together environments where people can enjoy the atmosphere that a portable music and light show can exhibit. The system will contain a rechargeable battery system for portability, will have Bluetooth audio receiving capabilities for convenience, but will also have wall powered components because of their high power consumption. One of the primary things that sets Essence of Music apart from other Bluetooth audio systems is its light show capabilities. There are plenty products on the market for Bluetooth audio systems, but many of them don't have anything special to bring to the table other than their standard speakers. With the fully programmed 32x16 grid of LEDs synchronizing to the music, Essence of Music serves to make the listening aspect of music turn into a spectacle as well.

In addition to the audio and video output, one of the primary concerns that comes with design of the system is its portability and usability. Because this is such a key factor in the product, Essence of Music will be easily transported regarding both the weight and size of the project box. One shouldn't have to worry about sending the young kids to transport it because that lets one leisurely enjoy handing out more chores to the younglings in the family in order to bring one their musical experience.

With looking forward to the future of contemporary music listening, Essence of Music can potentially lead the way in terms of music projects to be displayed around the workplace or home. The lithium-ion charging kit implemented in Essence of Music will guarantee that one will always have their pleasure on the go. If one ever has the need

to show off their flawless taste in music and style, Essence of Music will be there to support them in their happy endeavor.

2.0 Requirements Specifications

There are a few requirements to cover in regards to Essence of Music and what is required out of the system. Software specifications include programming a microcontroller to control the LED light display to and being able to take in signals from an analog audio input source for input settings and music input. Power specifications must meet a sufficient power supply for all components within Essence of Music without short-circuiting any of the components and being within the designated power limit of 80 Watts. Sound playback specifications need to meet audio feedback standards that most audio device on the market have - therefore there must be a 60 dB audio output requirement, which is the about the loudness of a regular conversation. Hardware requirements need to meet size standards that all components and sub-components fit together for portability needs and that there is a method to input setting and an audio input into the device without the need of a phone application.

2.1 Software Requirements

The Essence of Music software will need to be able to interact with the microcontroller to communicate with all of the major components of Essence of Music. The user interface will primarily be located on a mobile device, most likely an Android device, or on a computer that is capable of using Bluetooth. As such, the device will have to be user friendly lending it to be used easily by new users and people that are just starting to use mobile devices. The microcontroller will also have to be able to utilize information from the user devices in order to operate various aspects of Essence of Music.

The first requirement that needs to be implemented is the communication between the microcontroller and the speaker system and LED lights system. This will serve as the foundation of the device allowing for the microcontroller to manipulate the various components of Essence of Music.

The next requirement that needs to be addressed is the communication with the phone or web application. The audio signal will have to communicate with the microcontroller in order to send the audio information to the system so that it can be used by the microcontroller for the L.E.D display and the speaker audio systems. Communication with the handheld device is of the utmost importance due to the fact that the majority of the functions of Essence of Music can only function after having received information from these devices.

Setting up the LED light patterns is another key part of Essence of Music. The LED lights need to be programmed with the microcontroller in order to provide various patterns that will be displayed. It will be displayed in a 2D square grid consisting of 512 different grid units. (32x16) This is the main part of the visual display of the device regarding what the user will see when finished making changes to the device.

The final requirement that needs to be completed is the interpretation of the audio signal from the device for playing back music and other sounds. The microcontroller will have to be able to receive the audio signals from the application and mobile device and send the appropriate signals to the speaker system which will then be further divided to go to the various speaker systems.

The overall specifications of the software are to be able to interpret signals that come from the application and then sent to the microcontroller. Regarding just the application, there are many different types of mobile devices, even when limiting usage to just Android devices. Ranging in screen sizes from under three inches to over 10 inches and having various amounts of RAM, limitations that take these into account are required. The limited RAM on the microcontroller is also an issue where the Essence of Music team will have to be able to set all of the possible patterns and signal coding while remaining within the available RAM. Ensuring that the team remains within the physical limitations of the mobile devices and the microcontroller are the final components that must be covered in order to fulfill the specifications.

2.2 Power System Requirements

Regarding the Essence of Music power system specifications, the system needs to have a finalized ability to run for a period of five to seven hours on one full charge. The reasoning behind why lithium ion batteries were chosen is because they have one of the best energy-to-weight ratios which is very important for meeting the requirement of

portability for the design plan. Another important reason as to why they operate so perfectly for our design ideals is that they have a slow loss of charge when not in use, which, once again, is important for the portability and ease-of-use of the final product. One thing that is important about lithium ion batteries, to note, is that they are dangerous if not implemented correctly. They can easily be short circuited on accident and cause explosion. If the batteries do not have a stopping mechanism once they start losing voltage, you can also permanently damage the battery which reduces its total charge capacity. Due to this fact regarding the lithium ion batteries, it is essential to have a control mechanism for the charging and discharging mechanics of the batteries. It needs to be forced to shut off once the voltage on the batteries starts dropping, and the charging also needs to be stopped once it is at near full capacity.

It is necessary that the power system be able to power all of the aspects of the system continuously without any power failures that would interrupt usage of the system. Because of this, the Essence of Music team set the goal of the system using 20 Watts of power during maximum power output times. If it is needed to expect 20W power during operation, then in order to get five hours of usage out of the device the team can do some simple math to see what battery capacity is needed to power this system.

$$\begin{aligned}
 P &= \text{Watts} = 100W \\
 20 \text{ Watts} * 5 \text{ hours} &= 100 \text{ Wh} \\
 \text{Watts} &= \text{Volts} * \text{Amps} \\
 \text{Watts} &= \text{Volts} * 1000\text{mA} \\
 \text{mAh} &= \frac{1000 * \text{Watts} * \text{hours}}{\text{Volts}} = \frac{1000 * 100}{5} = 20,000\text{mAh}
 \end{aligned}$$

Once again, this is all assuming the actual operating power is less than 20 Watts and would be using 5V batteries.

After consideration, this is far too much capacity and something must be wrong with these conditions. Many batteries are in the range of 1000 mAh to 5000 mAh per storage cell, and because projects similar to Essence of Music's design ideal have clearly been met, something is most likely wrong about the above calculations. The assumption that is most likely incorrect is the 5 Volt output always maxing out at 5 volts instead of being an RMS value as well as the fact that much less than 20 Watts

could be used after design completion. From a simplistic perspective, speakers use very few Watts - in the range of 1-30 (varying highly by size) and the LEDs vary in power consumption from only a few Watts up to about twenty. (Depending on the brightness expected and how many are being powered)

Upon further inspection and thought on the topic, the primary calculation error is likely due to the incorrect assumption about how much power will be utilized at one point in time by the device. Over time during the research process, it was noted that many batteries for mobile applications are measured in mAh instead of Wh, and the assumption that the device would be using less than 20 Watts of power should not be how the energy system should be considered. Instead, the system needs to be seen in terms of the currents that are being drawn throughout the circuit.

2.3 Sound Playback Requirements

When referring to speaker level outputs, zero decibels is the volume level at which the human threshold of hearing occurs. One decibel is roughly the smallest change that a human can perceive. That being said, with respect to Essence of Music, it is necessary that the audio levels are approximately what people would expect to desire to hear in an open-room environment. Therefore, target audio level for maximum volume is intended to be in the 60-80 decibel range at one meter distance from device. One common thing to note with audio output that people perceive is that doubling the power does NOT double the actual audible volume of speaker outputs. Human hearing is on a logarithmic (decibel) scale.

Another important requirement of the speaker output system is the ability that it must have a multiple-speaker output for base frequencies and midrange/ tweeter frequencies. Having this crossover system consisting of Butterworth low-pass and high-pass filters will significantly increase audio output quality of the system to make the experience significantly more enjoyable for users.

In order to get the speaker output to be a level suitable for hearing, it is important to implement an amplifier for the audio signal in order to give outputs that would be suitable for a room or party environment. It is not common that a regular woofer hooked up to the output of an analog audio signal would be loud enough for the environment envisioned for Essence of Music. This ties into the whole active versus passive filter scenario that which is to be discussed later, primarily in the research and

design sections. The sound playback requirements tie into the power requirements in the sense that increasing the supply power can increase the power in the speakers - however it is not a linear scale in the sense that doubling power on the speaker does NOT double the loudness of the playback device.

2.4 Hardware Requirements

The hardware of the system needs to perform various actions. The first of these actions is to provide the system with the ability to power the system.

Aside from providing power to the system, the hardware also has to take in the audio signals and prepare them for use by the microcontroller. The audio signal will only be read in from a single source and has to be split to different destinations. Furthermore, the signal will have to be treated in different ways before it gets to the target destination. Hardware will be required to improve the audio signal for both the microcontroller and the speaker system.

Another key feature of the hardware is the ability to control the patterns and color on the L.E.D display. The hardware settings are required in order to provide the user with a method of affecting the patterns on the L.E.Ds as this option is not available on the handheld device. This is due to a combination of Bluetooth communication restrictions and available hardware options out of the microcontroller. Among the options that the user will have control over are: volume, speaker power, L.E.D patterns, and L.E.D color schemes. The patterns and the color schemes will be pre-coded into the system and cycled through using an external input system taking the form of a button.

2.5 Design Constraints

An important part of the design process is paying attention to realistic design constraints such that it meets realistic economic, health & safety, and manufacturability possibilities. Since this product is aimed to be more of a household leisure item, there is an important economic constraint in the sense that no sane consumer is going to buy a blatantly overpriced piece of hardware if it is orders higher than what a consumer expects - for example a \$1000 price point is not realistic and there is a constraint in the production process requiring the design materials to be in more of a realistic price range. Because of this fact, we are limiting the production cost of the finished product to be below the \$300 price point. During the development and testing process it is

assumed that much more than this will be spent, however the final product should be reproducible for under \$250.

3.0 Research and Background

Before going into specific design procedures for the product, the Essence of Music team found it really useful to absorb as much information from similar systems so in order to have a rough idea of exact capabilities/ possibilities that should be considered while going forward. It is important to have an in depth understanding how much power different components will require, how much power needs to be produced to meet these requirements, and how to transfer the proper amount of power to each component in the system. Different microcontrollers, speaker system, and LED options will be evaluated in order to come to a decision as to what best meets Essence of Music's requirements. Communication methodologies such as Wi-Fi and Bluetooth will be compared and contrasted as well as a comparison between the advantages and disadvantages between using a phone application or a web application for use with Essence of Music. All these different options will be evaluated while still taking into consideration size and weight aspects for portability and convenience in a room environment.

3.1 Similar Projects

Upon looking up other similar projects to what Essence of Music's design ideals are, it seemed that lithium ion battery systems were by far the most popular. Upon inspecting what is required, a five hour lifespan is absolutely needed, and judging by the different components that are to be likely used, at least 20 Watts between power speakers, the microcontroller, and the other components that require power. The actual power consumption is difficult to predict but as a high estimate the 20 Watts specification was a good point to choose. The team plans on using 18650 batteries that have a capacity of roughly 2500 mAh each. [1] Judging from many LED strip systems, the power requirements will be roughly similar to those - and some LED strips use in the range of 5W obviously depending on how big the system is and how many LEDs there are. While reading up on more projects of similarity, it seems apparent that LEDs are very popular and there are beyond thousands of projects out there that utilize LED light

shows. How can people be blamed? LED light shows are amazing and enjoyable to look at.

Just as there are many LED projects to relate to, there are also many, many do-it-yourself Bluetooth speaker projects that incorporate Bluetooth as a way to play music from a mobile device. Not only that, but some of them could be produced relatively cheaply (some as cheap as the ten dollar to fifteen dollar range. [2]

3.1.1 Sound Playback Projects

When looking into other sound playback projects, there were many different designs that consisted of a few different parts/ design constraints. USB Bluetooth 3.5mm Stereo Audio Music Receiver Adapters were common - and for good reason. They are a super cheap option considering they are around the five dollar price point range and it also contains the integrated circuit for receiving and establishing Bluetooth connectivity. Not only does it do all of this, but it also has a 3.5mm standard output which can be altered.

Two of the previous projects noted above were primarily related to the sound playback aspect of the Essence of Music team's design that can be considered when discussing final parts to include in the finished design of Essence of Music.

One specific design that was found was a simple circuit in a small box that consisted of a 3.3 Volt lithium ion rechargeable battery pack, a small lithium ion charger integrated circuit, Bluetooth receiver, amplifier, and two eight ohm speakers. The project was started by creating a frame to contain all of the electronic devices, using a hot glue gun to create a solid framework for all of the components. This included sawing holes to keep the woofers in as well as leaving space for the electronics.

3.1.2 LED Display Projects

There are many LED projects out there in combination with microprocessors, but not many of them have taken that extra step to go along to the music. That being said, there is a lot of information to gather and note from similar projects and experiments. In one particular project the configuration setup included the Atmega328P microprocessor, a 12 Volt wall socket power supply, breadboard, a few TIP31

transistors, a USB host cable and an Android device. [3] The functionality of the project included a small application on the Android device that could control the color of the LED light strip which was inside a sign in order to be able to change the color of the lights inside the sign. What's important to note about this project that will end up being similar to Essence of Music, is that three separate wires going to the Atmega processor were used in order to have color control over the LED strip. The microprocessor was programmed to use pulse width modulation in order to control the output signal on the red green and blue aspects of the LED strip. A one-meter long strip at maximum power could be used to draw about one amp of current - which, as a side note, is important to take consideration of since the Essence of Music team will be limited in the power aspects of Essence of Music due to its mobility requirement. If the full LED strip is to be powered for a full five hours (from the requirements), then the LED strip alone (neglecting the amplifiers, the microprocessor, and the speakers) would require 5000 mAh. That being said, that calculation comes from the assumption that the LED array would be using its maximum power at all times - which it will likely not be doing. There is also something interesting to note when regarding the power required for the LED strip - the maximum safe current output from any pin on the Atmega microprocessor is 40 mA, meaning this is much too low to actually power the LEDs alone. Because of this, the TIP31 transistors are needed in order to amplify the power to the LEDs. A simplified schematic of their setup is in Figure 3-1.

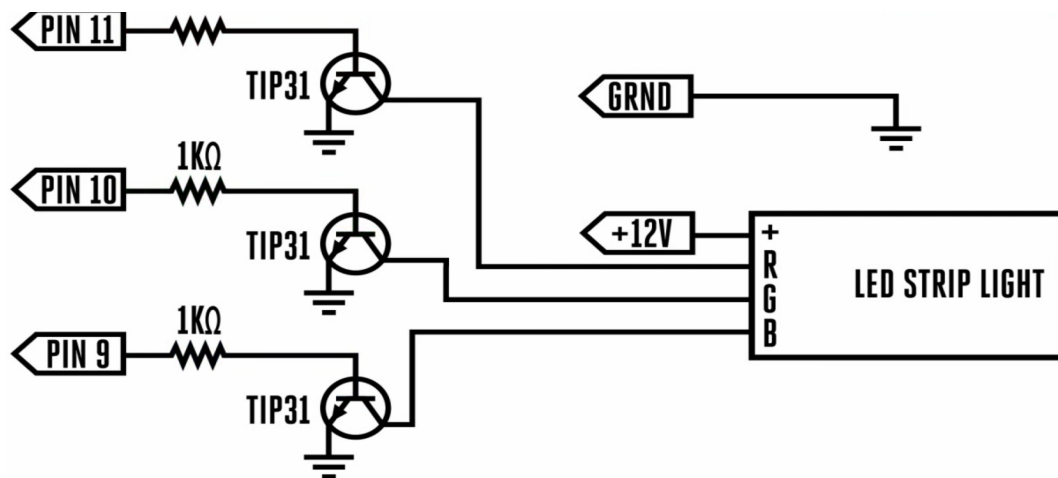

Figure 3-1 Example RGB Wiring
Permission Pending

Once set up, the device could send inputs from their Android device to the Arduino using the Arduino Color application. These colors were then sent to the board which

had PWM control signals setup to go from the Arduino board to the bipolar junction transistors. The circuit setup magnified the current to be sent to the LED strips.

Upon further inspection, there were more LED projects that were found to be applicable and helped in educating similar logic to how our circuit would be configured. In the following setup, TinselKoala (YouTube username), setup a system that takes in an analog input, and uses some of the processing capabilities of the Arduino to control a digital line output. This developer actually had five different sketches to show examples of some of the functionality you can do with an analog input and how you can program the microcontroller to do digital operations based on an analog input. Essentially the analog input gets read in as a ten bit number to the MCU, and his different codes have functionality programmed to operate differently based on that number that goes from 0 to 1023. In one of his examples, he uses his potentiometer (which is his analog input in this system) to control the rate at which the LEDs went through a cycle to light up. [4]

After researching more into the Arduino and example projects that deal with converting analog inputs into information that can be controlled by the MCU, it was noticed that Arduino.cc has snippets of their own code that can be useful as examples or for learning purposes.

The above code's functionality is to take in an input (and in their suggested configuration would be the voltage from VCC which is being divided between a 10 kOhm potentiometer. When the potentiometer is set to 10kOhms, the V_{in} to the sensorPin (A0) in their code will be 5 Volts (the same as VCC), and the input value would be 1023 (which is sensorValue). In this scenario, the ledPin would alternate between HIGH and LOW every 1023 milliseconds. This trend would work for any value of the potentiometer, meaning turning the potentiometer all the way to one side would result in very fast pulses for the LED while all the way to the opposite end on the potentiometer would result in very slow pulses of the LED.

3.1.3 Wireless Control Projects

One of the key requirements from our projects is wireless control over the music, but wireless control over other aspects is an interesting topic to discuss for added customizations that could potentially be added to the Essence of Music. While looking

into wireless control projects, there was a couple examples of how others setup their television remote to be able to control household devices.

In the appendix, we have example code of how we plan to execute this. The developer used this pin layout to an Arduino in order to be able to send control signals. [5] The box on the right is an IR receiver diode - the TSOP38238 to be exact. This device cost about two dollars therefore the setup is very cheap and easy. Outside of the IR receiver node, they clearly set up the circuit using a diode going to Pin 2, two 100 Ohm resistors, a 10kOhm resistor, and a bipolar junction transistor. After all the hardware is obtained, the Arduino board in their configuration was programmed using the IR library that was developed and is online for public use by Ken Shirriff. Jason Smith (the person running the project walkthrough) then showed you can hold down the temporary push switch to put the circuit into programming mode for the TV remote. While holding down the switch, press a button on the TV remote, and then that will successfully control the digital pin 2 on the Arduino. Once it is programmed, the board can be connected to any household appliance or outlet and the TV remote button will toggle the switch on and off.

This can relate to Essence of Music if it is decided to add the functionality of IR controls for the device. Applying the concepts learned from Mr. Smith's project, all that would need to be implemented is a button to be able to program the Essence of Music to users' home TV remotes, and then they would, for example, be able to control the on/off switch for Essence of Music using a TV remote control.

3.2 Speaker Construction and Design

As time goes on, there are more and more speakers to choose from to implement into Essence of Music. The following section will discuss the advantages and disadvantages of different types of output devices to be connected to our system in order to give us the best audio quality for the price, size, and power of the system. The primary factors to take into consideration is the power that is able to be supplied to the speakers, the environment in which the speakers will be running (for example what type of reverb is desired), and how the speakers will be physically attached to the project.

What is still up for debate is whether it would be better to produce its own specialized equalizer for the types of music that is planned to be used most, and if the Essence of Music team does choose to implement it, decide to either implement it on the analog

side of the audio signal or the digital side of the audio signal. The perks of digital filtering is that the crossover has a significantly flatter frequency response relative to the errors that occur from creating analog butterworth filters (for example it's impossible to have 100% accuracy in the resistors and capacitors used in the analog aspect of the filter. That being said, analog filters have a couple advantages respectively. Advantage number one is that analog processing can be done very fast - a computer can only filter data as fast as it can sample the audio using FFTs whereas simple op amps can operate past even 100 kHz. Though, it is worth noting, most humans cannot hear past 20 kHz regardless. The second advantage of analog over digital is dynamic range. This comes in two flavors. Amplitude dynamic range is the ratio between the largest signal that can be passed through a system, and the inherent noise of the system. For instance, a 12 bit ADC has a saturation level of 4095, and an rms quantization noise of .29 digital numbers, for a dynamic range of about 14000. In comparison, a standard op amp has a saturation voltage of about 20 volts and an internal noise of about 2 microvolts, for a dynamic range of about ten million. Just as before, a simple op amp devastates the digital system. [6]

After looking at the advantages and disadvantages of hardware and software filtering for the sound playback system, it is more straightforward and sensical to make use of integrated circuit hardware crossovers instead of digitally filtering it because it will lead to a more satisfying audio playback experience.

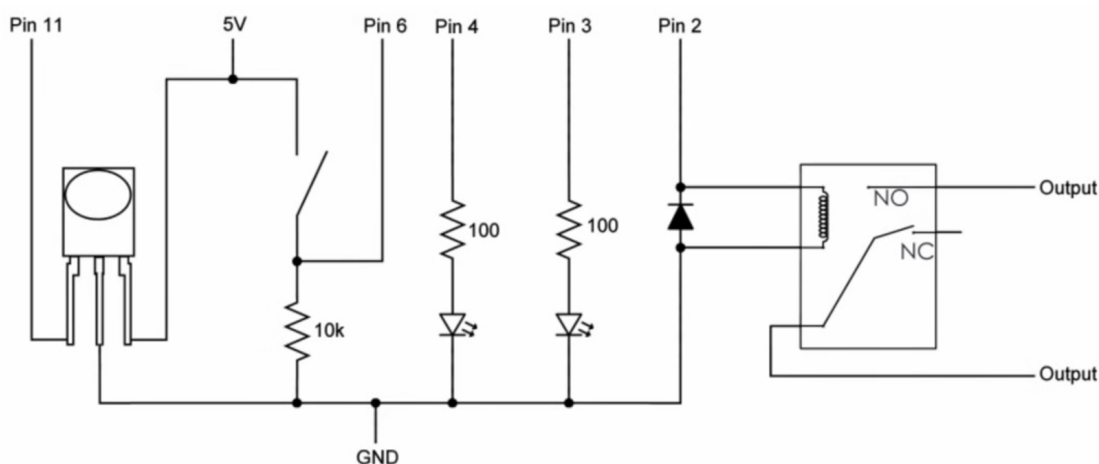

Figure 3-2 Digital vs Analogue Crossover
Permission Pending

3.3 Power Systems

In reference to powering the system, the first concern is considering what components all need to be powered. The list of components that need to be powered is as follows: the Bluetooth and/ or Wi-Fi receiver, the analog to analog converter, the physical speakers, the amplifier, the microprocessor, the LEDs, and any transistors or other circuit components that might burn power during operation of the device. When looking at the power system of Essence of Music, it is essential to remember the different requirements of the system. One of the primary concerns are if there should be a dedicated battery for mobile operation, or if Essence of Music should rely fully on wired power. One of the main concerns for using a battery for mobile operation is making sure that the battery is current/ voltage limited in order to avoid explosions/ unstable operation. According to the stated specifications, it is essential be able to operate the system for a stable five-hour timespan. A concern that could potentially be an issue is constant power output as the battery drains. It would be very undesirable if the audio or LED output decayed as the battery lost its maximum energy. The light show is required to have a constant brightness level that is enjoyable to the user.

Judging from similar projects and other systems in existence, a standard 5 Volt input should suffice when it comes to powering the system. After some extensive research, it seems that there are a few options for mobile powering. Option number one would be simple 1.5 Volt AA batteries in series using a battery pack. The primary downfall of this option is the fact that to get to a 5 Volt input it would require four to five 1.5 Volt AA batteries, which could turn out to be expensive (or inconvenient) in the long run to replace. [7]

Although AA batteries would be a surefire way to get the Essence of Music powered, they can turn out to be costly and might not be the most suitable option for the design ideals of Essence of Music. Upon comparing different alternatives for battery power, the Essence of Music team decided to turn towards a lithium ion rechargeable battery system. Because the system is intended to be portable, convenient, and modernized, it is only proper that it has a rechargeable battery system; therefore the decision was made to implement rechargeable lithium ion batteries as power for the system.

The following is the list of reasons why a lithium ion battery setup is perfect for Essence of Music. First, lithium ion batteries can be found in many different shapes and sizes; for this reason, it is suitable to the project because portability is an issue at

hand, and having a correctly sized and/ or shaped battery can permit extra flexibility for the final output size of the project box. Lithium ion batteries also have little memory effect in them - meaning if the batteries are charged to one-hundred percent from fifty percent, it will not affect the total storage size of the battery. Not only do lithium ion batteries refrain from having memory effects, but lithium ion batteries also have a much lower self-discharge rate (about five percent per month) compared to nickel metal hydride batteries and nickel cadmium batteries which have over thirty percent and twenty percent per month of discharge respectively.

Although there are many benefits to using a lithium ion battery configuration for Essence of Music, there are of course going to be a few disadvantages that are worth noting. One of the unique drawbacks is that the lithium ion battery lifespan is actually dependent on the time since manufacturing regardless of the number of times it has been charged and/ or discharged. Another aspect that controls the lifespan of lithium ion batteries is the charge capacity that remains when left idle. If a laptop battery is left at room temperature for a month with full charge, it will irreversibly lose about twenty percent capacity per year. If a laptop battery is left at room temperature for a month with half charge, it will lose four percent of its maximum capacity per year - therefore it is much better to leave lithium ion batteries at less than full charge if it is planned to be left idle for long periods of time.

After further research about Lithium Ion/ Polymer batteries, it is important to understand how the batteries' output power/ voltage worked over time. (With respect to the capacity) and found some incredible content discussing how they operated and a couple of small differences between some of the ones that are on the market. Dave Jones from EEVBlog mentioned a lot of useful information regarding the charging and discharging of Lithium Ion batteries. [8] One thing to note is that it is possible to permanently damage the batteries to fully discharge them (and can also be dangerous), so the Essence of Music team needs to make sure to implement some type of control in order to prevent the batteries from being drained completely. The below figure shows the discharge profile of a standard lithium ion battery, and in this particular case, the Panasonic NCR18650.

Discharge Characteristics (by temperature)

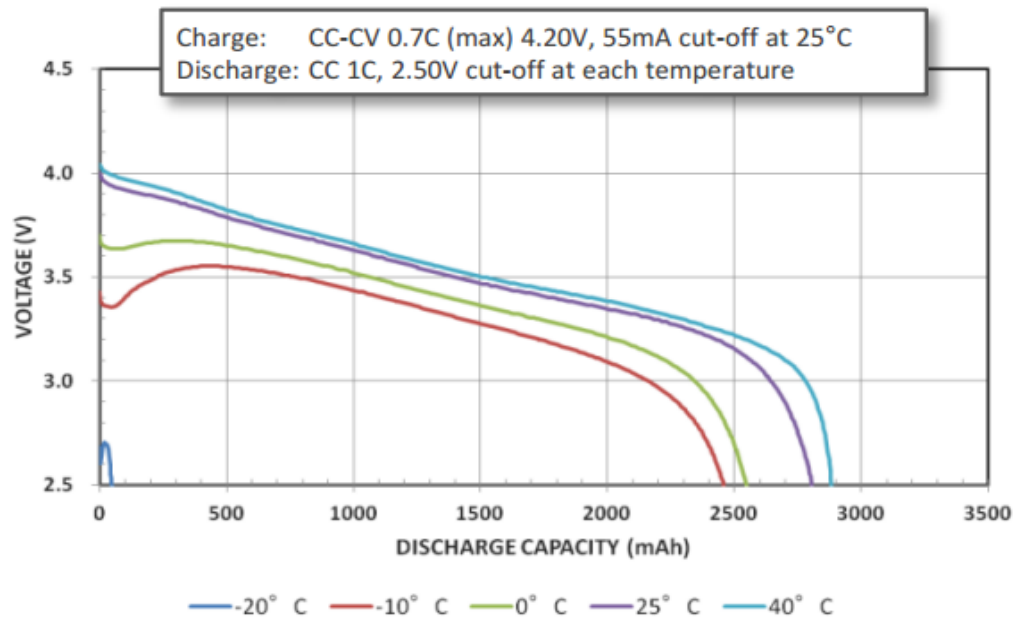

Figure 3-3 Battery Discharge Characteristics
Permission Pending

There are three stages to the charging of Lithium Ion batteries. The first stage is when the battery is drained too low. (Technically this stage shouldn't be used often since if the battery is already that low, it could be potentially damaged). The second stage of the charging process is the constant current stage. This stage of charging lets the battery charge relatively quickly while also being safe to the battery. Once the battery reaches a certain percentage of its capacity, it switches over to the third stage of charging which is the constant voltage stage. This stage lets the battery fill until it is at its maximum and lets the current decrease until the battery is considered fully charged. Below is the standard required charge characteristics from Panasonic's NCR18650.

Charge Characteristics

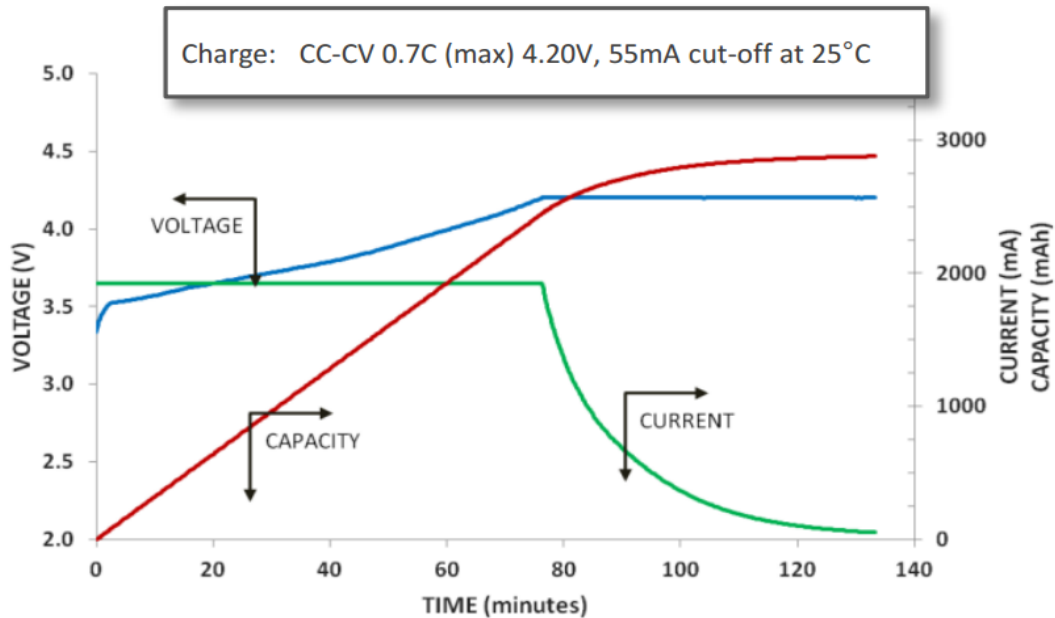

Figure 3-4 Ideal Charging Characteristics for Panasonic 18650 Battery Cells
Permission Pending

Although 18650 battery cells seem to be very common, it is important to pick the correct ones. From current understanding, it seems that charging lithium ion batteries requires a circuit that knows when to stop charging, controls the charging rate, and in general ensures that the batteries are being charged in a safe manner without being overcharged or receiving too much current when charging. There are multiple integrated circuits on the market that can execute the correct charging requirements for the 18650 batteries. For testing purposes, there are easy kits that can be used to recharge and use the batteries during the testing process. Easy kits will be necessary because the final design of Essence of Music will have the batteries be internal, there will be no way to implement the battery charging station inside the device.

Although the design decision is to use lithium ion batteries to power the system, it is important to also realize that Essence of Music will need a few DC-DC conversions considering different components will need different input voltages during operation. According to (above video), the theory behind DC-DC converters is discussed and how they're designed and mentions how there's current movement towards IC DC-DC converters. They also discuss how IC converters differ from discrete DC-DC converters. More important to mention is regarding parasitic induction. It discusses

how the duty cycle of the DC-DC converter causes “parasitic induction” in the wires of the PCB because of the small inductive and resistive properties of the wire. When operating at very high frequencies (which many FPGAs have been starting to do), the converters can cause parasitic induction that simulations will not monitor such as LTSpice and Multisim. [9]

Since the output voltage of the battery slightly decreases relative to time (or battery capacity), it is required to have a DC-DC converter that “lowers” the voltage of the battery to a stable voltage in order for correct operation of Essence of Music. In the Essence of Music’s design situation, the Essence of Music team is going to use a Step down 5 Volt switching power DC-DC converter module after configuring the batteries to be in series to get a nominal DC power source of 7.4 Volts (3.7 Volts from each 18650 after placing the batteries in pairs of two in series).

Another option when deciding on supplying power to the system is to enable the system to be able to be hooked up to an external 5V power bank. Over the last couple years, portable USB power banks have been becoming more and more popular - and for good reason; more and more electronics are becoming wireless. However, one gap that has yet to be filled is the ability to supply wireless power. Alternatively to having internal 18650 batteries which have to be taken care of. (Because of the dangerous aspects of overcharging or overuse) To setup the external power supply, there would simply be a male USB power input on the outside of the box that could connect either to a phone charger or to a mobile power bank. The primary advantage of this setup is there is no worry about needing to recharge the device, the device is simply powered by whatever outside system is setup. Since portability is a concern, it might be more convenient for users to use a power bank for desk setup, but if the user is able, then Essence of Music setup in this configuration can also work with any source of USB power. USB power can be obtained from a simple phone-wall charger that converts the outlet from 110 Volt AC to 5 Volt DC, or the device can also connect to a laptop or portable power bank.

3.4 Wireless Applications

A desired goal for Essence of Music is to incorporate a wireless application for the user to input different settings for the device and to use as an interface to transfer audio signals through. There are two lead candidates for a wireless application to go hand in hand with Essence of Music. The first option is a phone application given the wide pool of users that carry smart phones (Android) and different wireless capabilities that phones already possess. The other option is to create a web application as most people have a connection to the internet in some form. Careful consideration will be taken into account for the necessary communication methodology necessary to make either option work.

3.4.1 Phone Applications

When comparing the various methods that one can use in order to manipulate the various settings on a portable device, a phone application is one of the first to come to mind. This type of design allows the Essence of Music team to code an application specific to a platform for use with the microcontroller and other key hardware. The main advantages of using a phone application as opposed to a web application include: the ability to perform a more specific action that a web application cannot perform, the ability to perform more complex calculations, greater compatibility regarding the offline communication with the project product, and, perhaps the most important specification in this case, it has the ability to be used without an internet connection.

The project device is a separate entity from the application entirely and needs to communicate almost fully through the use of wireless communications. An application allows for greater control of specific functions if coded correctly. If the application is able to access the wireless capabilities of the phone device, the Essence of Music team can use a dedicated phone application in order to perform most of the functions that the device is capable of performing. However, if a pure phone application is utilized, then the issue of requiring data management would arise in order to store all of the required software and memory on the device.

The other big thing that the Essence of Music team would want to be able to do with a phone application is create a larger amount of personalization regarding the control of the device. This would be more easily achieved when using a phone application as

opposed to a web application. However, there is also the possibility of including updates to the software capabilities which would be meticulous on a phone application.

The other big reason to create a phone application is the market that smartphones occupy in the economy is growing. According to International Data Corporation (IDC), the worldwide market for smartphones has grown about 13% “year over year” and in the second quarter of 2015, 341.5 million phones shipments were made [15].

Some recent numbers show that Android devices had about 82.8% of the smartphone market in 2015 Q2 with a key factor seemingly being Samsung focusing more on “lower-cost” smartphones [15].

3.4.2 Web Applications

Creating an application that utilizes a website in order to function is the other option for controlling the device. This type design choice would allow the Essence of Music team to utilize a website in order to control the device at the cost of requiring a steady connection to a network.

One of the major advantages that would come out of using a web application is the ability to perform updates on the web application without having to impact the user devices with frequent updates to the app. Being able to update the application also provides the Essence of Music team with the ability to adapt it to changes in the user tastes regarding patterns and other visual effects on the playback device.

However, the ability to push updates onto the web application is mitigated by the fact that the playback device would also have to be updated just as frequently. In the event that the playback device becomes damaged or the wireless capabilities are disrupted, a web application would be incapable of working correctly with the playback device. If the web application is solely used, this is an issue that would have to be addressed.

One of the key advantages that the web application has over traditional phone applications is the fact that it is accessed through the internet and a browser on a device. Creating a web application allows for an expanded usage of the application from phones to other internet devices so long as the playback device is also on the same network. An expanded audience is a big plus, and makes it so that the device

can be accessed by more than just phones to include laptops and perhaps even internet/ SMART televisions.

Of course, the main issue with this is that the devices would have to be on the same network and areas without internet connections or those with restrictive ones could cause major issues with controlling the device. Losing connection to the server or network would require a backup of some kind in order to keep the device running.

Coding of the website will likely use basic methods including JavaScript, PHP, and MySQL. These would allow for the use of tools to simplify the application creation and are rather easy languages to learn and utilize.

3.4.3 Decision

While a web application provides more flexibility regarding use on multiple devices and an online database, a phone application will probably be the primary choice. The Phone application, while restricted to a single device without specific coding designs, is more mobile and would not require a connection to the internet in order to use it. Furthermore, a phone application still encompasses a large group of people even when restricted to a single device type such as Android. Using only a phone application also drops the requirement of connecting to the internet in order to complete various tasks. It also frees up the possibility of forgoing Wi-Fi connections in order to communicate across both devices. Wi-Fi could then be replaced solely with Bluetooth in for use as a communication tool. If time allows, a web application can be implemented, but the phone application is currently the desired target.

3.5 LEDs and Display

An essential component to the design of the project is the lighting. The entire purpose of the project is to create a light show that synchronizes with the music being played. The most obvious solution is to use light emitting diodes. (LEDs) LEDs use less voltage and power than most conventional lighting technologies. There are many different types of LEDs, but across the board they are cheaper than other light solutions, and with Essence of Music requiring so many different lights (256 approximately), they are an obvious choice. LEDs also come in many different sizes, but the standard for most is small, roughly 5mm, which works well with desired portability aspect of Essence of

Music. LED technology has come a long way over the years. As such, there are many variants of LEDs to choose from to pick for the Essence of Music's needs, and extensive research is required for each type.

3.5.1 Miniature LEDs

Miniature LEDs come in a variety of sizes, typically between 2mm to 8mm. With a simplistic design, they are easy to use and do not overheat like other types of LEDs. The small size of these LEDs and simplicity are advantageous to the Essence of Music's portability design goals. Unfortunately, however, the LEDs' simplicity also prevents them from being more than a single color. While this is not necessarily a deal breaker, it will require the Essence of Music team to place three separate LEDs into each individual square unit, having them appropriately wired. This alone makes this type of LED not desirable as it innately undoes the advantage of their miniature nature. In addition, since each individual LED color runs on a different voltage levels, this makes the wiring even messier as there are 256 position on the grid, requiring more room inside the device and adding to the overall size and weight.

3.5.2 High Power LEDs

High-Power (HP) LEDs are LEDs that run on comparatively high current levels. (Can be around an entire Ampere compared to the 10s of mA that other LEDs run on) HP LEDs, as the name suggests, use a lot of power and output a lot of light. They are typically used in electronics that the purpose is for high lumen output such as flashlights. The high power usage is not efficient nor desirable with the project's goals and the high lumen output is highly unnecessary for the light display. HP LEDs seem to only be made in white. This is also a problem as the project requires a variation in the visual lighting. Over-all, HP LEDs would not work for the Essence of Music design.

3.5.3 RGB LEDs

RGB (Red Green Blue) LEDs are probably the most commonly found LEDs in this day and age. These LEDs are technically three different LEDs built into one. The design of these LEDs has four wire connections, with either a common anode or cathode as the longest lead from the LED. (Shown in Figure 3-5) Another possible design, though

much less common is a two lead design with a built in micro electronic control unit. The standard in terms of size of these LEDs is 5mm. RGB LEDs in general are a good idea to choose for Essence of Music as they offer a near limitless array of colors given the appropriate voltage levels running through the device. Their size of 5mm fits in with size specification of the project.

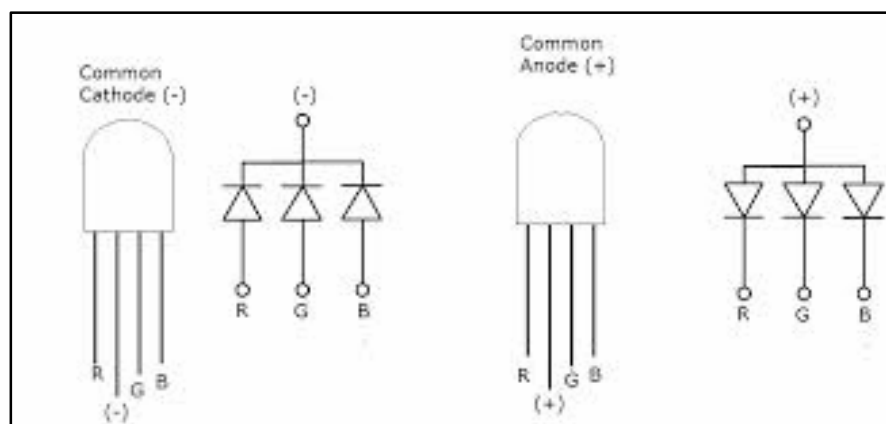

Figure 3-5 Circuit Diagram of RGB LEDs
Permission Pending

There are other factors to consider with RGB LEDs as there are different types of RGB LEDs. RGB LEDs come in both oval designs and square designs. (Shown in Figure 3-7) Oval LEDs emit a fairly consistent level of light throughout its entire body with the exception of the bottom. The lack of light does not pose an issue as the only actual need for light in Essence of Music is from the top. Square shaped LEDs are as the name implies, square in design, but with an oval dome. The sides are typically more opaque than the oval dome making it harder to pass light through. Since Essence of Music's light show display is only a 2D fixture. Square RGB LEDs are the more desirable of the two as they are easier to place side by side and the only clear light source that is necessary is from the top of the device.

3.5.4 Flashing LEDs

Flashing LEDs are a unique type of LED. Coming in all different types, such as miniature, high-power, and RGB LEDs. The key difference that flashing LEDs have are quite plainly, the flashing or blinking instead of maintaining a continuous light output. Beyond the flashing aspect of this kind of LED, the required voltage level, size of the

device, and other various factors are all the same as their non-flashing equivalent LEDs. The flashing aspect of this LED is not desirable to the requirements of Essence of Music as the LEDs need to have a constant output. Now, it may be possible to achieve the desired goals by designing a clock for the LEDs and possibly placing at least two different flashing LEDs into the same square unit within the LED grid of Essence of Music, but this would impose an entirely new dimension to programming the LEDs to the input music of the device. On top of the additional programming complications, the overall cost would go up for Essence of Music due to the number of LEDs and the size of each grid square would need to be larger. Flashing LEDs are a poor option for Essence of Music as flashing LEDs would impose unnecessary work and constraints to the design of the project.

3.5.5 Digital LEDs

Digital LEDs are RGB LEDs that have a built in chip. These kinds of LEDs are typically sold as strips of LEDs, but individual ones can also be purchased. With an integrated chip, the LEDs have a data input and output. This is why the LEDs are sold in pre-packaged strips as one LEDs' data output directly connects to the next LEDs' data input. The first LED in the strips need to be connected directly to a microprocessor to control the specific details for how the strip will work. Digital LEDs simplify many factors in the design for Essence of Music as it eliminates a lot of the excessive wiring. With the need of 256 different LEDs, (One per grid box) the removal of excessive wiring goes in concordance with Essence of Music's requirement goals of being portable by reducing size and weight. The downside to digital LEDs is that due to the extra complexity, the price is much greater than any other type of LED. This increase in price is worth the exchange as the beneficial factors far out way the increase in cost.

There are many different kinds of Digital LEDs on the market. Each one is named after the type of chip that is used within the strips. The most common is the HL1606. The HL1606 uses low voltage levels, around five volts, throughout the LED strip. Each individual chip usually controls two different LEDs within the strip. Another common Digital LED is the WS2801. The WS2801 tends to be more expensive than the HL1606 model as more are required through the strip because this particular model's chip can only control one LED per individual chip. It runs a similar voltage level as the HL1606 and offers a much greater array of colors. (Roughly 16.7 million) Another common type on the market is the LPD8806. The LPD8806 runs an even lower voltage level

throughout the strip than the HL1606 (Around 3.3 volts) and similarly to the HL1606, each individual chip controls two different LEDs within the strip. Less chips throughout the strip makes the LPD8806 significantly cheaper than the WS2801 but only slightly more expensive than the HL1606. It offers significantly less color variations than the WS2801. (2 million) Due to the significantly higher price of the WS2801, it is less desirable than its counterparts. Though it does offer more colors, the large variation is not necessary as most people do not notice minute color variations. The HL1606 and the LPD8806 are superior options with the lower pricing and low voltage requirements. Either of these two variants would work well with Essence of Music and are both viable options. [10]

3.5.6 Decision

Based on the different types of LEDs available on the market, digital LEDs are the obvious choice as they offer the most benefits in every direction except for cost. The HL1606 or LPD8806 are equally viable digital LEDs. If digital LEDs are not applicable, the next immediate choice are RGB LEDs that have a square casing. Though these will require an extreme amount of extra wiring compared to digital LEDs, square RGB LEDs offer the desired range of colors along with meeting size requirements and the square shaped design allows for easier grid placement.

3.6 Microcontrollers

There are many different types of microcontrollers available for us to use. However, each of them has their own quirks and peculiarities that allows one to be more proficient in some aspect over the other. The microcontroller that we plan to use needs to meet a few key qualities: the ability to send signals to both the L.E.D grid and the sound system, have the power and memory required in order to run the code that we want it to be able to run, and be easy enough to work with given our limited design time.

When first discussing what type of microcontroller to use, it is very important to understand the differences between different types of controllers in order to see what would fit Essence of Music's design goals for the best price and quality. The primary two microcontrollers that have been taken into consideration are the Atmega328P which is produced by Atmel, and can be easily programmed and/ or setup using Arduino project board. The other microcontroller is the MSP430G2553.

The primary advantage of the MSP430 setup is the cost, being that some of the ICs are in the \$3.00 range while the Atmega328P microcontroller ranges from \$4.00 to \$6.00 depending on vendor. Having a cheap price for these increases profit per unit if a device were to be sold as well as helps the development process in the situation where some microprocessors used might be burnt out from being implemented incorrectly - just in case. That being said, there are other advantages to the MSP430. Another important reason to develop using the MSP430 for a portable product is because it operates at 3.3 Volts instead of the Atmega chip that operates at 5 Volts. Making sure that power consumption can be minimized will only benefit all parties involved.

Although there are some definitely valid reasons to value the MSP430 over the Atmega328P, there is still a few key things that keeps the Atmega option a very valid one. Primarily, although Texas Instruments is a massive company, Atmel has a lot of support for its products because it has a huge community base that is constantly sharing ideas for projects and designs. Because of this, the design process could turn out to be much easier given that more help is readily available to Atmega consumers.

Another small difference between the two that is worth noting is the different coding that has to be done for the two controllers. The controllers can be programmed relatively similarly using C or C-like language, but they of course have different IDEs. That being said, there are actually third party companies/ developers that have created a system for launching the Atmega code onto MSP430 (Energia.nu). To be more exact, directly on the homepage it is labeled that "Energia is also a portable framework/ abstraction layer that can be used in other popular IDEs". [11]

There is article after article discussing the ins and outs, advantages and disadvantages, and every tiny difference between the two platforms, but at the end of the day there are a few standardized specifications that differ between the two. (Shown in Table 3-1)

MCU Features	Arduino/ Atmega328P	Energia/MSP430G255 3
Architecture	8bit - RISC - Harward	16bi -RISC -Von Neumann
Power supply	5V	3.3V
Flash	32KB	16KB
PINs	28	20
Timers	2	2
PWM pins	6	3
RAM	2KB	512B
Clock	8 MHz internal or 16 MHz external	16 Hz internal + optional low speed external

Table 3-1

Comparison of ATmega328P and MSP430G2553 Microprocessors

From the above specifications given from the two pieces of hardware, it is apparent that the MSP430 technically slightly less powerful in terms of the RAM, Flash, and number of PWM pins. The MSP430 wins over in the category of the internal clock and the number of bits in its architecture, but the architecture is by no means “better”, moreover that it is different. When looking at our particular design ideals, power is also a very important topic of discussion. The ATmega328 being a 5V device will mean that it will demand slightly more power than the MSP430 version, so it is definitely worth looking into both parts towards Essence of Music. Where the MSP430 truly prevails is in its incredibly low price of purchase. From the various vendors that could be looked up, ATmega328 price ranges around the \$4.00 to \$6.00 range, with Digi-Key seeming to be the cheapest at \$3.38 per unit while a few other vendors are around \$6.00 such as from some of the sellers on Amazon that claim to have the Arduino bootloader already installed. [12]

When first looking into the Arduino/ Atmega328P microprocessor choice, it was important to take into consideration all of the factors that would have design impacts

on the device. To give an exact explanation regarding what exactly the ATmega328P is, it is quoted to be a “low-power CMOS 8-bit microcontroller based on the AVR enhanced RISC architecture. By executing powerful instructions in a single clock cycle, the ATmega328P achieves throughputs approaching 1 MIPS per MHz allowing the system designer to optimize power consumption versus processing speed.” [13] This device is astonishingly powerful considering the price, power dissipation, and processing ability given everything inside the given circuit. It of course has a fully functioning AVR CPU, timers, oscillators, A/D converter, and many other components that would be relatively impossible to develop given the time and cost requirements for designing the Essence of Music. The below figure shows an overall block diagram of the device that includes many of the internal components as well as what inputs are able to be passed to the device.

Of the 28 pins on the ATmega chip, there are six PWM pins that can be used to control or simulate non-digital output such as in the case of desiring to control our LED system. This is another clear advantage of the ATmega chip compared to the MSP430 which only has three PWM modulated outputs. Each RGB output that would connect to our LED strips will require three different input connections that will connect to our microcontroller. In other words, if we desire to have two separate color lights going on at the same time, then it is required to have six pins dedicated to those - which the MSP430 cannot supply and in that case the ATmega chip will be required. It is for the above reason that the finalized design decision is the ATmega328P.

While checking over the datasheet for the ATmega328P, a core piece of information that will greatly impact the performance of Essence of Music was found - minimizing power consumption (page 42 on Atmel’s data sheet). There are several possibilities to consider when trying to minimize the power consumption in an AVR controlled system. In general, sleep modes should be used as much as possible, and the sleep mode should be selected so that as few as possible of the device’s functions are operating. All functions not needed should be disabled. In particular, the following modules may need special consideration when trying to achieve the lowest possible power consumption. The ATmega328 is incredible in terms of power usage in its idle state - using a mere few micro amps of power draw when sleeping.

3.7 Communication Methodology

After initial inception of design came up, the Essence of Music team knew that sending data from a mobile phone device was a primary concern. What needs to be done is to understand the different design philosophies that might make or break the decision between a few different options when transmitting data from the user's device into the final project. Even though Essence of Music is expected to have wireless functionality, it is still vital to be able to have standard 3.5mm input audio from a cable coming from a phone. For that exact reason, Essence of Music was also required to have a standard wired input line. Whenever hard wiring anything to a smartphone - it's important to be sure that there is a short circuit protection mechanism in order to protect the smartphone for obvious cost and ethical reasons. The following sections will discuss further the logic, advantages, and disadvantages behind a few different transmission protocols that are being considered.

3.7.1 Wi-Fi

Using Wi-Fi as the method of communication between the user device and the playback device would allow the device to have access to a rather large number of networks allowing for easy access to the internet and online databases. Wi-Fi is also a widely spread technology and can be found in many places from restaurants to hotels and dormitories.

Wi-Fi's biggest advantage with regards to the device is the ability to connect to more devices and network points. Since there are many Wi-Fi locations and even new devices that enable phones and other such devices to act as a network source, Wi-Fi would be able to allow the playback device a wide selection of communication methods.

However, while the many connection option is definitely a positive with regards to the device, some other issues may arise from this. Open networks may have many users on them and reduce the bandwidth that the device can have access to. Furthermore, relying on Wi-Fi communication between the playback device and the mobile device could result in unsteady connections or even easy hacking of the device depending on the type of security that is implemented.

Wi-Fi also presents a problem in having multiple devices connected at the same time on the network. Essence of Music would have to have a unique way to address itself on the network if Wi-Fi is used as the device communication method. This would be similar to having multiple printers with the same name on a network and not knowing for certain which device is which without looking for further details about each individual device.

Incorporating Wi-Fi into the device appears to be rather simple. Texas Instruments has several ICs that could be used for the system with prices that appear to be less than .06 for a set (6.70 for 1 ku). The Wi-Fi ICs seem to be designed in such a way that they can be easily connected to a board and allows “any low-cost low power microcontroller to [connect to] the Internet of Things.” The CC3100 chip from TI is an example of such a chip that allows for such connectivity and is a Wi-Fi certified chip with a dedicated ARM MCU for performing wireless instructions separate from the microcontroller.

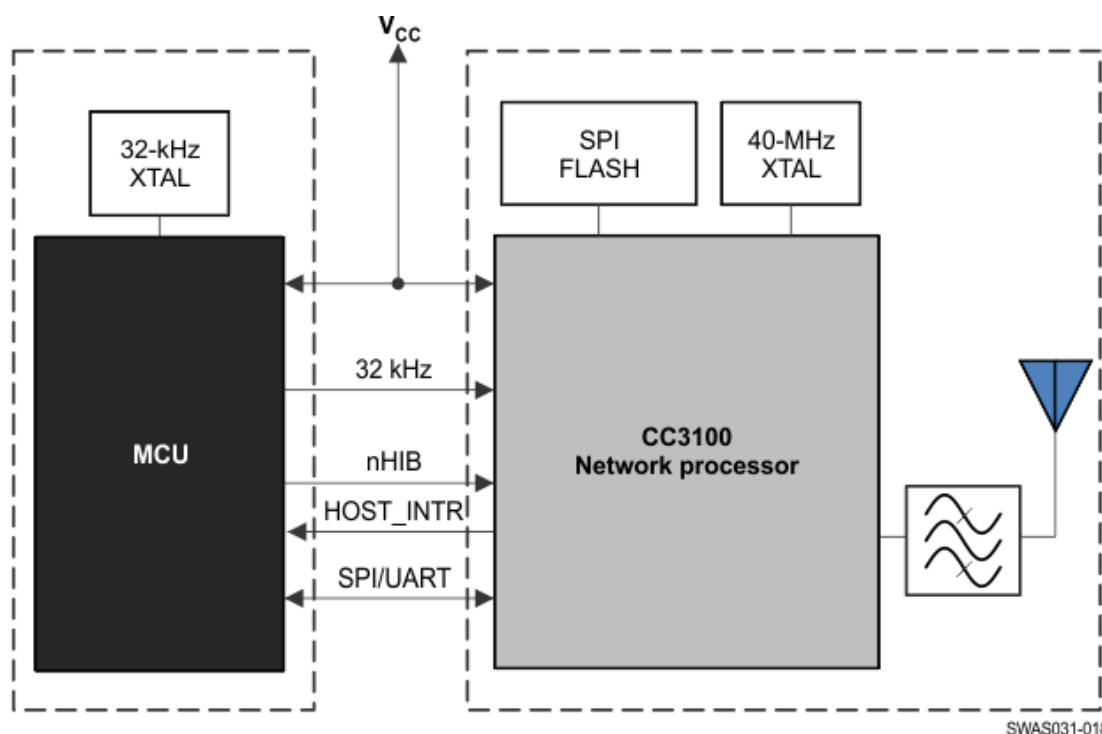

Figure 3-6 Example CC3100 Wiring Format Suggested by Texas Instruments
Permission Pending

3.7.2 Bluetooth

Using Bluetooth as a method of communication between the user device and the playback device provides Essence of Music with several key features. Bluetooth is already incorporated into many other devices and as such allows Essence of Music to utilize features that already exist on other user devices. Furthermore, the nature of Bluetooth requires the pairing of devices in order to operate, meaning that outside user can be potentially avoided from syncing with the playback device and controlling it.

One of the key features that Bluetooth has is the relatively low power cost. With the advent of Bluetooth 4.0 and higher, the power efficiency of the Bluetooth circuits has increased by a meaningful amount. This low power version of the Bluetooth device is also able to send a data at higher bit rates while also maintaining a reduced power consumption. For Essence of Music, incorporating this into the device would be a huge boon since it means that the device itself would have to divert a smaller amount of energy to the Bluetooth IC in order for it to function, allowing for more energy to be supplied to the LEDs and speakers. The CC2564MODN module that might be utilized also has features that allow it to save energy by entering a sleep mode or shutdown mode to save power when possible.

The prices for the Bluetooth chips also appear to be rather low. The CC2564MODN Bluetooth module sells for 6.65 per 1 ku meaning that it costs a little over 6 cents per unit and sampling of the device is available. This device is a 4.1 spec Bluetooth module and is a likely candidate for incorporating a Bluetooth module into the device. Since the module is a 4.1 spec version, it has the benefit of being a LE version meaning that the energy cost of using this module are rather low. Furthermore, the cost of acquiring the rights to use Bluetooth is relatively small for a product such as this one.

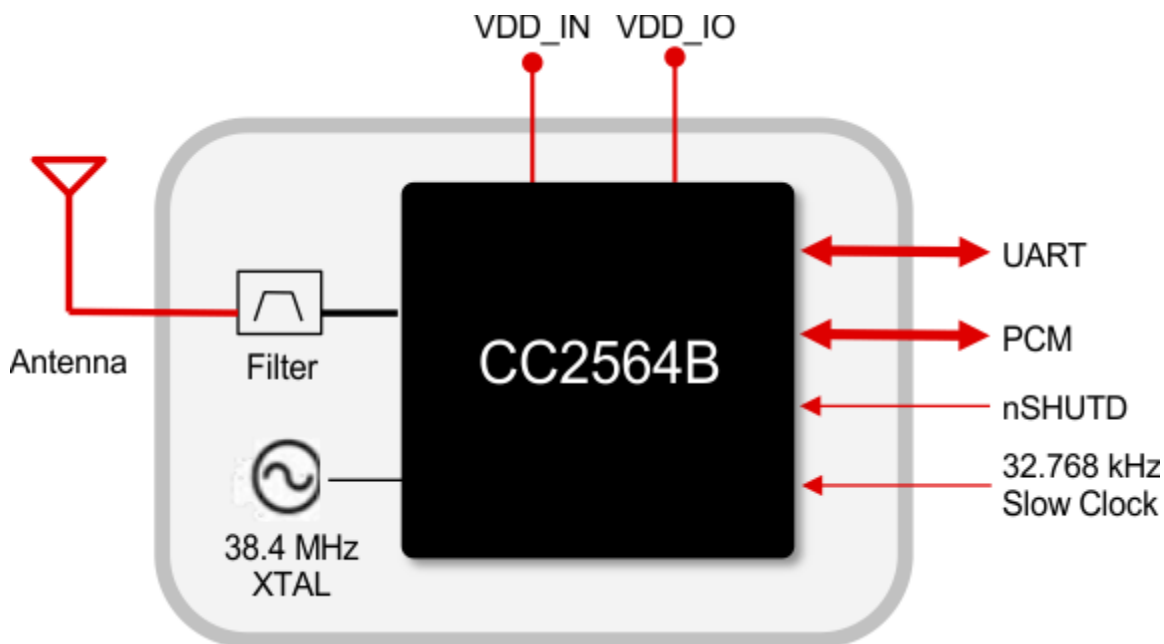

Figure 3-9 Wiring Format of CC2564B 4.1 Bluetooth Module
Permission Pending

Figure 3-9 also has several features that would aid in the operation of the device. Aside from being a relatively low power module, it is also able to connect to up to 10 devices at one time. This, combined with the potential to operate in a Bluetooth device mesh would allow for connectivity to several different devices. The most direct boon for the Essence of Music team with this feature is the ability to allow for multiple users to interact with the device simultaneously. However, this would also mean that the Essence of Music team would have to manage how the data is received and whether or not other users are able to make modifications to the device while it is active. Having multiple users controlling the device at the same time could result in the playback device having a lower overall impact due to constant switching of media and data.

The system is also able to provide a longer range of use than some other Bluetooth devices with the product description claiming that it has a range that is twice that of other BLE-only solutions.

Another reason that Bluetooth is viable is the fact that Bluetooth Technology is being incorporated into more and more devices that see daily use. This means that fewer users would have to acquire a device that has the ability to connect via Bluetooth. Bluetooth is incorporated into so many devices such as phone, personal computers and televisions, that the use of Bluetooth in our device could mean that these devices could operate the playback device as well. Furthermore, the nature of the Bluetooth

device is to connect devices that have Bluetooth capabilities together without overburdening the network of devices that they create.

However, while Bluetooth does have several useful features, there are some big drawbacks as well. One of these drawbacks is the lack of ability to connect directly to Wi-Fi. The module featured above is a 4.1 spec model which boasts higher bit rates and lower power consumption but does not have the ability to communicate directly to the internet. However, this does not mean that Bluetooth cannot connect to the internet at all. The primary way for a Bluetooth device to connect to the Internet is to use the Wi-Fi capabilities that exist on the device already. This allows for the device to use the Internet without the use of Bluetooth. However, if the device does not have access to Wi-Fi, it means that the device would require another device of some kind that has the ability to connect to the Internet. The device in question would have to be Bluetooth compatible and have Wi-Fi capabilities for this to work. The Secondary device would connect to the Internet and act as a hub for other Bluetooth devices to connect to the internet. The device would serve as a bridge between the device and the internet.

While most Bluetooth devices are not able to connect to the Internet without the use of W-Fi or another device, there is a new spec of Bluetooth, the 4.2 spec, which is able to connect directly to the Internet without the use of either secondary method. This spec was released in December of 2014 and is being incorporated into many new devices today [16]. If we could incorporate this spec of Bluetooth into our Playback device, it would increase the options available to the user.

An alternate method of receiving Bluetooth input that seems promising is using generic Bluetooth USB audio receiver IC as the receiving method. These products are cheap, functional, and can easily be modified with some soldering. The USB is only used for powering the chip, and in the case of Essence of Music's power system, could be setup to connect to the 5V rail instead of requiring actual USB connection for power. The output of the device is the standard 3.5 mm audio male to male cable that can be cut open and wired to the input of our amplifier system as well as to our microcontroller for our lighting functionality.

Another potential issue that the Essence of Music team has found is that Bluetooth is a digital communication device. Since Bluetooth is going to be used as a wireless communication method between the user device and playback device, audio signals are being transmitted which means that the signals will need to be converted to and

from analog to digital in order to playback the audio. This means that the Essence of Music team would have to increase the complexity of the circuit design in order to get functioning audio.

3.7.3 Hardwiring

The option of using hardwired audio input on the device is to ensure that the device can be used in all situations regardless of network stability or availability. A hardware connection does not allow for the user to openly control the device from a distance and instead requires that the user interact with buttons located on the device in order to submit inputs for the playback device.

While hardwiring definitely allows for use of the device outside of a network, it also prevents the device from utilizing all of the potential features that connecting to a network and device would offer. The hardwiring would involve the use of a small set of buttons in order to read in some basic functions allowing for the use of basic patterns available on the device.

However, the use of hardwiring means that there needs to be a simple set of instructions available through the use of the buttons that provide the basic patterns available on the device. Furthermore, the ability to access the functions should not be lost to the user due to the complexity or difficulty of performing them.

3.7.4 Decision

From the research that the Essence of Music team has gathered, it appears that the most likely candidate for wireless communication is Bluetooth. However, this comes with the caveat of being able to correctly implement the 4.2 spec onto the device. In the case that the 4.2 spec is unable to be used and the 4.1 spec is chosen instead, Wi-Fi becomes a viable option for communication. Wi-Fi offers the ability to access the internet using the playback device directly which could draw from a database of information regarding possible patterns that can be accessed as well as offering the ability to connect to users on the same network. However, this comes at the risk of having a relatively public device which means that security measures would have to be implemented into the code.

In comparison, Bluetooth is able to connect with devices that have Bluetooth installed and communicate with them easily. However, this comes at the loss of being unable to connect to the internet unless the playback device is using a 4.2 spec Bluetooth device. This means that Bluetooth would have to rely on a separate device to communicate with the Internet in order to access any type of online database.

Another option is to incorporate both technologies into the playback device which would allow for more user flexibility at the cost of circuit complexity increasing. This option allows the team to use a Bluetooth 4.1 spec while keeping all of the benefits of having an Internet connection through Wi-Fi. The increase in circuit complexity would also mean that there would be an increase in the power consumption of the device which means that power would have to be regulated more closely.

While Bluetooth 4.2 and Bluetooth 4.1 with Wi-Fi are the most likely candidates for the wireless communication options, a hardwire set-up with a basic set of instructions (possibly more complex ones if time allows for it) is definitely going to be incorporated into the design. This design choice was made to allow people who don't have a wireless device, the ability to use Essence of Music without having to buy another product just to use Essence of Music. However, the limited options on the hardwiring side means that the device would only be able to display a certain set of patterns or selected data that is hardwired through the use of the buttons. Hardwiring also allows for the user to use the device without having to connect to the internet or another device. This gives the device usability even in areas that don't have sustainable Internet connections.

The final decision for the design of the system is to utilize Bluetooth communications in order to send and receive audio signals using the devices. This will allow for easy communication between the devices and also allow the user to easily find the through the use of the Bluetooth discovery function of most devices. This will be the basis of the audio communications. The hardware method will be used to modify the patterns and the color schemes that are available on the device. This will prevent any users from being unable to fully operate the device beyond having a Bluetooth audio source.

4.0 Project Design

Essence of Music is a conceptually simple device that is designed to play audio files while syncing it with an LED display. Users will be able to connect to the system through the use of Bluetooth and use the hardware available on the system in order to actually make changes to the patterns that are available. This will be done through the use of 5 main systems, each of which will fulfill a specific task in providing the user with an enjoyable experience when utilizing the device.

The system will primarily be interacting with the particular phone that it is synced with. The system is responsible for being able to receive incoming audio from a mobile device or computer, analyzing the audio data for visual display, exporting the algorithms to the LED array. As well as being able to execute these tasks, it will also have hardware buttons capable of volume control, power on/off, profile switching, and color scheme switching.

The microcontroller will have the duty of controlling the LED light grid and managing the other systems on the device. The microcontroller will control the LED grid through the use of multiplexers and by sending the appropriate values to the LED lights which will determine the colors that the LED lights will display.

The Power System of Essence of Music has the responsibility of sending power from the different power inputs and sending it to the systems that demand it. The power system also stores the rechargeable battery which will be designed to have enough power to run the audio amplifier to MCU as well as the MCU itself for at least five hours. The power system will be responsible for supplying energy to the various systems of the device given appropriate power levels.

The Sound System is the last major system of Essence of Music and is responsible for providing the user with the sounds that they are expecting to hear from the device. The system will take the signals from the Bluetooth receiver, which will be in the form of analog signals, in order to tell the speaker systems what sounds to produce. The audio signal will be played to the user via the speaker system's two main components, the stereo and the bass.

Figure 4-1 gives an extremely high level overview of how Essence of Music will work.

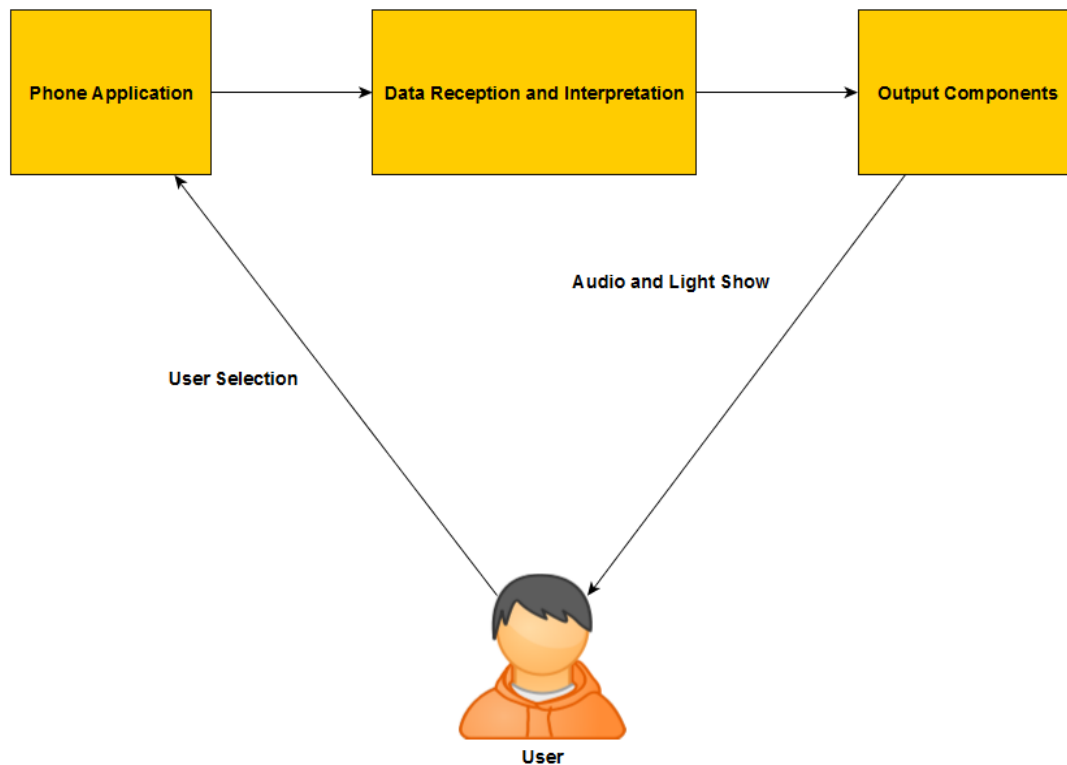

Figure 4-1 Flowchart of User Interaction

4.1 Hardware Design

It is important that everything gets designed to fit well together in the sense that battery life/power is not being wasted, the final product is easy for the user to operate, and that the system fits all requirements/specifications that were previously stated. As a quick list of qualities the device must follow, it must: operate for five continuous hours, it must be reproducible for under \$300, the user must be able to interact with the Essence of Music wirelessly through Bluetooth, have hardwired display alteration methodologies, all components of the device must fit within a volume of size 30x30x30 cm and be less than five pounds, and output at least 60 dB range within one meter in terms of audio output.

With these requirements in mind, the Essence of Music team will need to wire the power system directly to each individual system in Essence of Music. (Speakers, PCB/Microcontroller, LED grid, and Bluetooth receiver) The Bluetooth receiver will receive audio signals from the phone and send the appropriate data to the

microcontroller and the speaker systems. The microcontroller will then interpret the data and communicate to the LED grid what visuals to show. The speaker system will receive the audio signal from the Bluetooth receiver and output the signal for the user to hear. Figure 4-2 shows a detailed diagram how each individual system in the hardware will be communicating with each other.

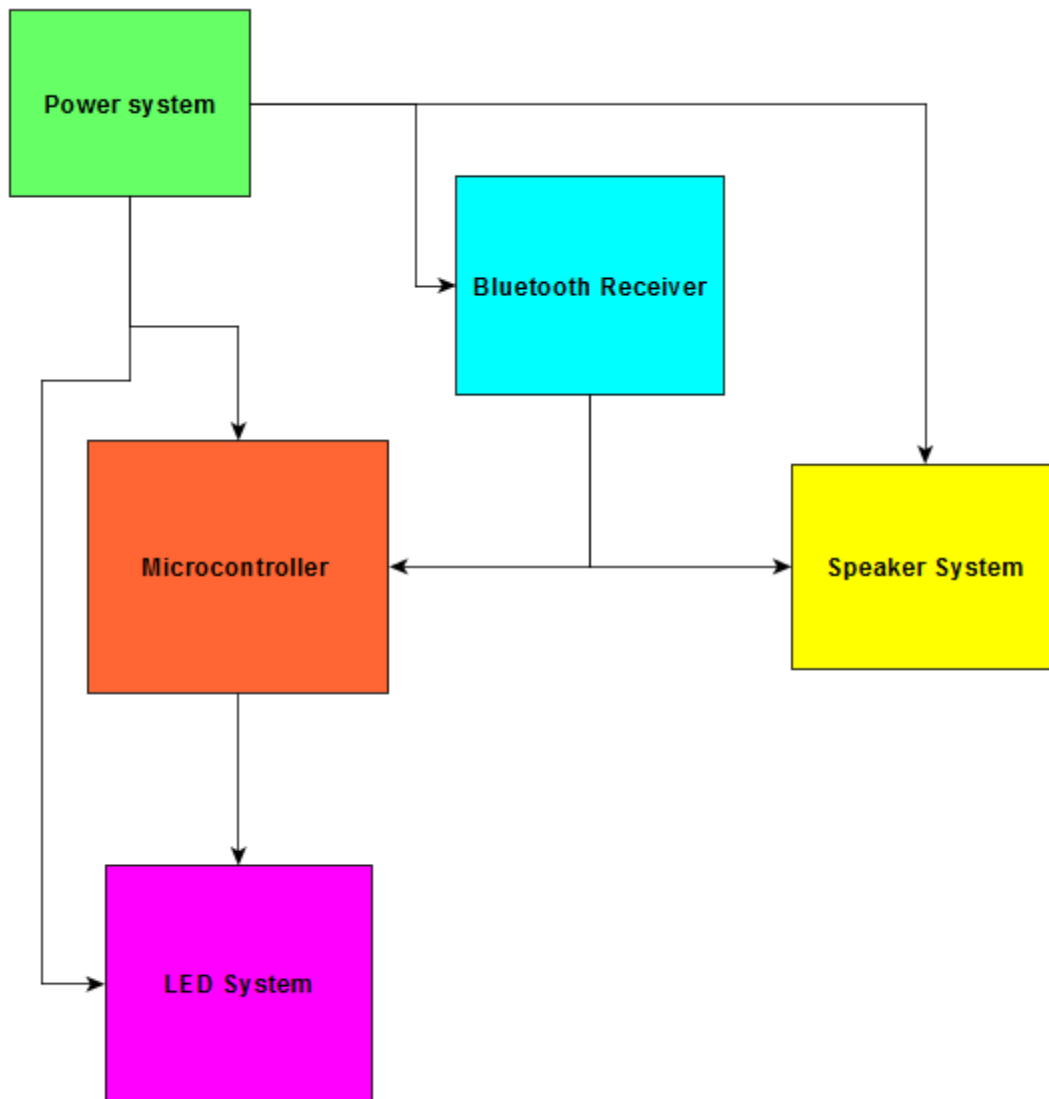

Figure 4-2 Overall Flowchart for Primary Systems

4.1.1 Power System

From the conducted research, there were a few different viable options for powering the system. However the primary decision is using lithium ion batteries with a backup substitute being an external power bank and/ or wired USB output to a wall adapter. When looking into rechargeable batteries in general, 18650 lithium ion batteries were the clear winner. From reviews, it seems that the larger manufacturers of 18650 batteries are significantly more reliable therefore those will be the ones purchased. The Panasonic NCR18650 has many positive reviews and is one of the more stable batteries on the market. Essence of Music will be equipped with six 18650s that each have a capacity of around 2500 mAh. This gives us a total storage of 15,000 total mAh for one full charge. To note, there is a lot of variance in true capacity of 18650s, so this actual value can vary from battery to battery. Because every part of the circuit operates at or below 5 Volts, pairs of 18650s will be run in series, and have the pairs all be in parallel to give more storage space. The power system will be wired as shown in the below Figure 4-3.

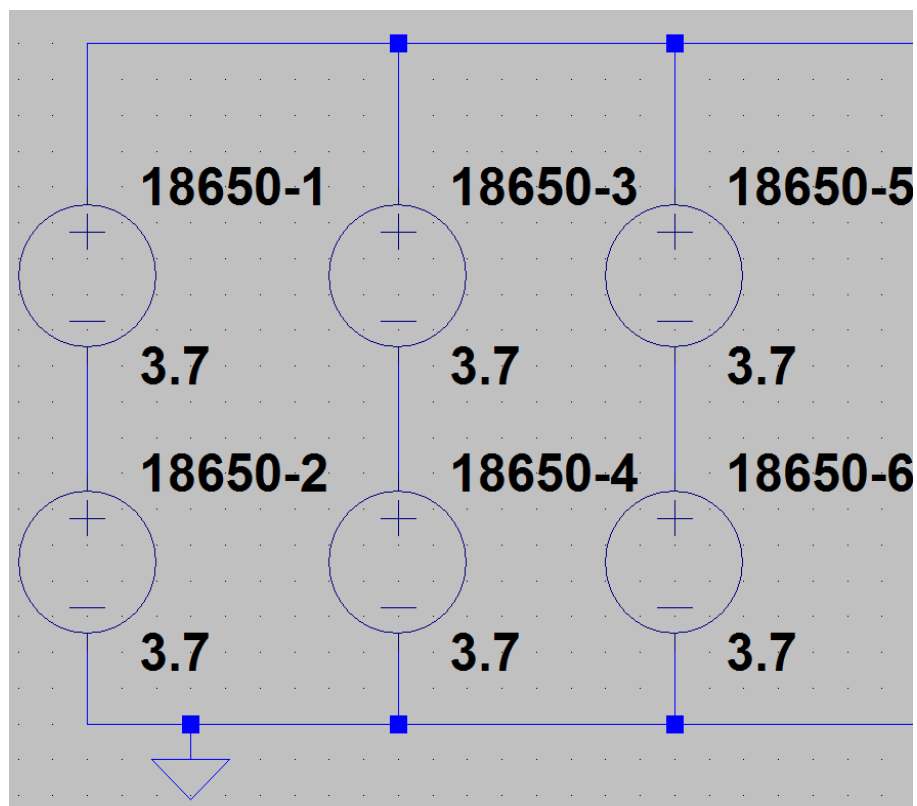

Figure 4-3 Panasonic 18650 Battery Configuration

Because the system will be implementing multiple 18650 batteries, a few things have to be kept in mind. 18650 batteries are very unstable if not kept under the correct operating conditions, especially in systems utilizing multiples of them. Importantly, one of the characteristics discussed during research was that lithium ion batteries cannot be overcharged. If they are overcharged, they can physically break, explode, burn, and in general cause permanent damage to the cell. Because multiple batteries will be implemented in parallel for increased capacity, it is important to have them power balanced. Regarding how to charge the batteries evenly, the group will be utilizing an iMax B6 to charge the batteries safely during testing phase. During the production phase and in the final product, the device will be utilizing a TP4056 circuit to charge the batteries properly. The TP4056 has a USB 5V input that allows the safe charging of the lithium ion batteries. The TP4056 also monitors the current capacity of the battery system and will automatically change colors between green and red depending on if that battery is above or below a certain energy level. To also make the product safer, a fuse will be implemented as a hazard precaution in case of a short that would demand power from the entire battery load.

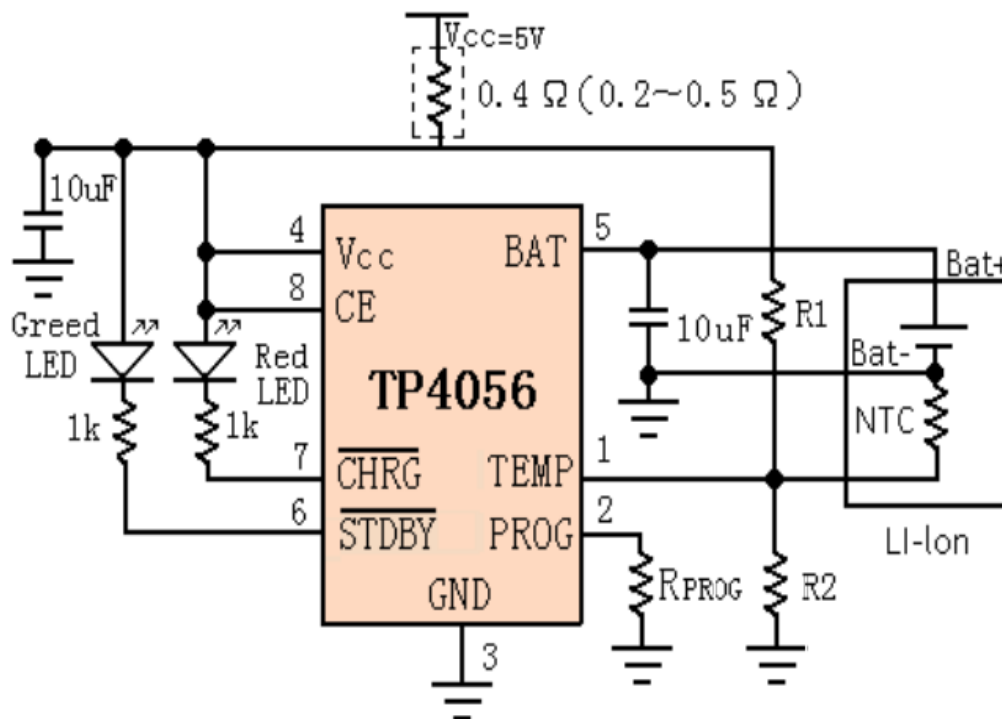

Figure 4-4 Charging Circuit to be Implemented to Safely Charge Panasonic Lithium Ion Batteries
Permission Pending

There are four primary components that need to be able to be powered - the speakers, microcontroller, Bluetooth receiver, and LED strip. In order to make the circuit operate cleanly, the Essence of Music team is using components that all operate on 5 Volt DC power. When designing the system, it is important to have an estimate of how much power each of the components can be drawing in order to ascertain a good estimate of lifespan of the device. The speakers are expected to be drawing an RMS value of around 11 Watts, so running at 5 Volts, would mean it draws about 2 Amps on average. After five hours, it is expected that the speaker system would therefore use a total 10,000 mAh worth of energy. Judging from previous projects, the programmed ATmega328 microprocessor can be expected to draw in the range of tens of milliamps during operation - after five hours of operation, it would still only use a maximum of 400 mAh (this would be with the assumption of 80mA being used at all times). From reviews from buyers from the expected LED strip, users are saying an average current draw of around 500 mA at the rated 5 Volts - therefore the energy usage for the LED strip can be expected to be in the range of around 2.5 mAh after five hours of operation.

Component	Current draw during operation (mA)	Total energy usage after five hours (mAh)
Speakers	2000	10,000
Microcontroller	80	400
Bluetooth module	80	400
LED Strip	500	2000
Total	2660	13300

Table 4-1 Essence of Music Estimated Power Usage

One comment worth noting is that with the values given in Table 4-1, so long as each lithium ion battery cell can store up to 2660 mAh worth of energy, then the five hour longevity should be reached properly.

Because some of the components will be utilizing too much power, our speakers as well as our LED grid will be powered by wall outlets to ensure stability of the system.

Running these components on battery will significantly shorten the lifespan of the device, and from a design perspective, it is preferred to have uninterrupted service rather than run only on battery.

The system should also be able to notify the owner of the device when the battery levels drop below a certain threshold. This threshold is ideally around 10-15% but can be adjusted if need be. Testing for this will be done by linking the playback device with a handheld device and checking for a notification when the battery levels drop below the threshold. Measuring of the battery levels at this point will give an indication of whether or not the test has been passed successfully. The test fails if the system either fails to send the device a notification or the device sends a notification when the battery has not drained to within 4% of the target threshold or has exceeded the threshold value by 4%. This test succeeding means that the device is able to accurately determine the amount of battery life remaining and inform the appropriate user about the remaining battery life without producing a disruption in the playback of the audio.

Also to note, the TL082 audio signal amplifier requires a positive and negative input in order to amplify the whole signal, so to power this relatively small component, two 9 Volt batteries will be implemented in order to supply the small power required by the device.

4.1.2 Speaker Systems

Because the focus of this project is not on the audio output quality, but instead more focused on the signal representation on the LEDs and wireless connectivity, we will be including a pre-built audio output amplifier stage in order to bring relatively high-quality output audio throughout the room without much noise or interference.

The loudness of the speakers is the primary concern when discussing the speaker system. We want to be sure that the user can hear the device from a nice distance away and that there is no concerns when it comes to the audio quality. Once again, because we are using an already developed audio

4.1.3 Microcontroller Layout and LED System

From the research conducted, it seemed most proper that our system implement the ATmega328P microcontroller for controlling the LED system in Essence of Music. The community support and the slightly more powerful hardware was enough to set it slightly in front of the MSP430 - which was the previous alternative. When looking into the final design, it is important to understand how all circuit components operate together.

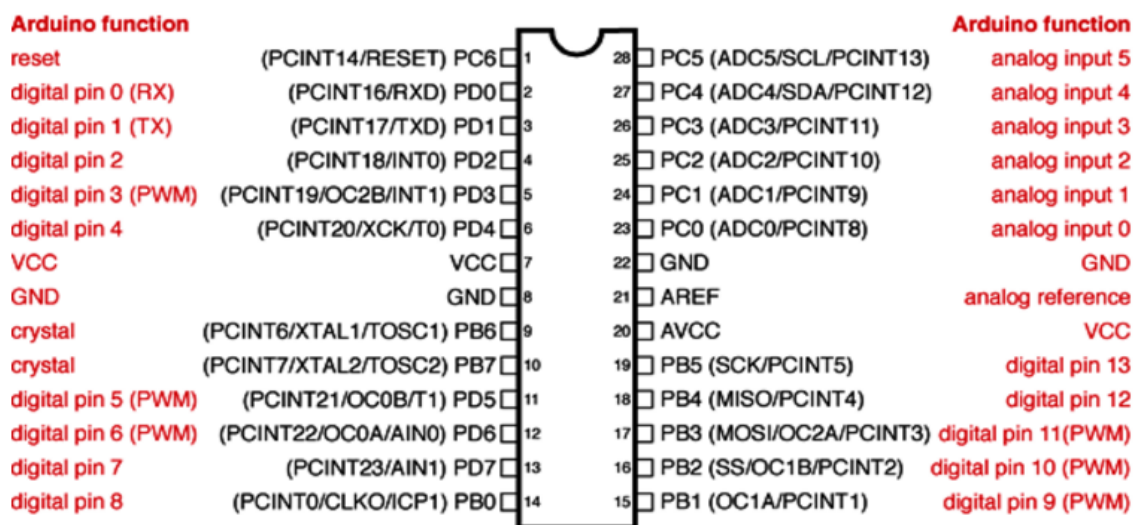

Figure 4-5 [30] Pin Layout of ATmega328P

Permission Pending

The figure above will be used as a reference for understanding where exactly everything should wire. The microcontroller is the most important when it comes to this topic for two reasons. One, it is the most costly component to replace if damaged. Most other circuit components are relatively cheap when compared to the MCU. Two, it is the most complex to setup to operate under our specific conditions properly. Because of this, it is vital to understand the pin layout and setup a plan regarding how everything will be physically wired.

Many of the digital LED strips found on the market have very similar specifications when it comes to power consumption, color options, and price per unit, therefore the Essence of Music team is going to be working with an Adafruit RGB Medium LED matrix strips that has thirty RGB LEDs per meter with either white or black backing strip. The microcontroller will then be programmed to light up this specific strip based on some of the inputs that will be received from the Bluetooth receiver. The strip works

best with input voltages of 5 Volts, which is perfect for the overall design because many of the components in Essence of Music operate at this standard.

The LED strip will be connected in three places - the 5V wire to the 5V rail, the DIN wire from the strip to digital pin 6 on the ATmega chip, and the negative wire to both the negative terminal on the DC supply and the GND pin on the ATmega chip. C code will be installed onto the ATmega chip with Arduino bootloader installed, and this C code will control aspects of the light that goes to different aspects of the music. Figure 4-10 will give a better visual representation of how the LED strip will be wired to the different components.

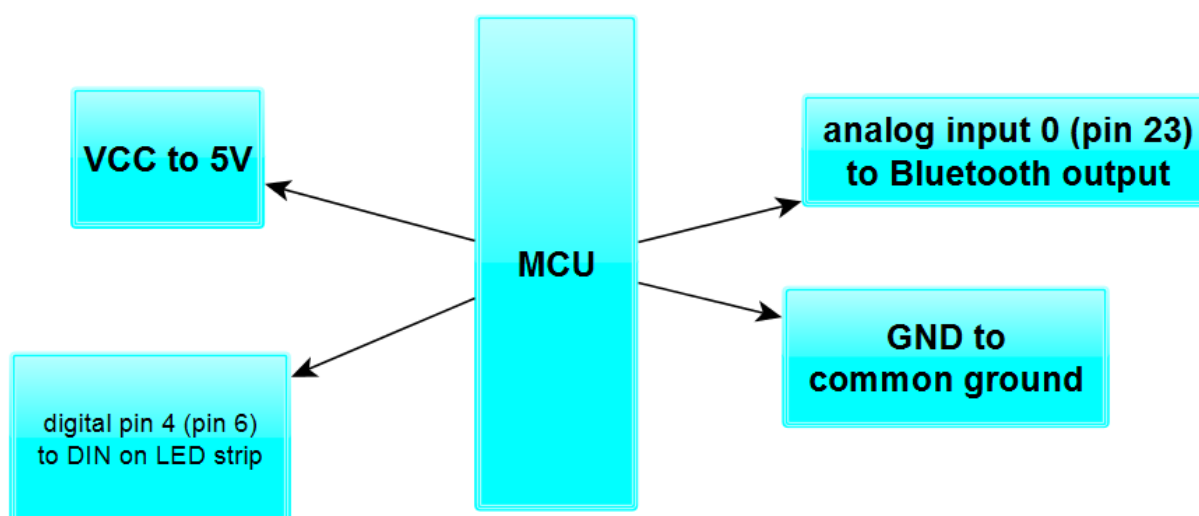

Figure 4-6 MCU Perspective of System

Figure 4-10 gives a better visual representation of how the setup will operate from the perspective of the MCU. Discussing the same topic from the perspective of the microprocessor, the microprocessor will be connecting to four objects. The VCC pin will be connected to the 5V input rail. The GND pin will be connected to the common ground of our circuit. Pin 6, which is digital pin 4, will be connected to the DIN wire from the LED strip. Then the last connection that the microprocessor requires will be analog input 0, which is pin number 23.

4.1.4 Input Signal Systems

There are a few different methods that audio input could be send to the device. The three primary ways are sending digital Bluetooth audio data, digital Bluetooth

automatically converted to analog, or to have an actual hardwired analog input on the device. The advantages of sending digital data to the device would be very convenient in terms of doing digital signal processing because we would not need to be using our MCU's analog to digital converter, and we could instead simply send the digital data over to it. The advantages of sending the analog signal into the system would be that it would have less noise going to the speaker output stage and would yield better audio quality. The advantage of having a hardwired input is that the user does not have to worry about pairing their device with Essence of Music and would be easy for the user.

After consideration, it was decided that we wanted to send Bluetooth analog input to our MCU and Speaker amplifier stage, so we decided to utilize the Aluratek iStream audio receiver. This device allows users to connect up to ten meters away, and allows the user to input whatever audio is playing from their third party device. Using this method, users do not have to worry about wiring up their phone, and they can play from any media outlet they desire - whether it be YouTube, Spotify, or other media sources.



Figure 4.7

Aluratek iStream image

<http://aluratek.com/istream-universal-bluetooth-audio-receiver>

Other inputs to implement are the pushbutton inputs that will be located on the sides of the case that will control volume, speaker power, pattern choice, and pattern color.

Essence of Music will have two different methods of receiving input for the system to function. The first method will be through the use of Bluetooth Communications which will allow for the system to take in audio signals to be used by the microcontroller for manipulating the L.E.Ds and the speaker system for audio playback.

The second input method will be the physical peripherals located on the side of the device that will provide the user with access to the L.E.D display manipulation and the audio playback controls.

4.1.4.1 Wireless Input

During the research process, different wireless communication protocols were looked into including Wi-Fi 802.11 transmissions as well as Bluetooth transmissions. Between the different advantages and disadvantages discussed in section 3.7, it seems best for the system to implement Bluetooth over Wi-Fi due to better power management and more straightforward implementation. Wi-Fi serves very few advantages that do not seem to make up for the extra costs that come from its implementation. In terms of the circuit we will be actually utilizing, Essence of Music will be integrating the standard USB drive audio receiver with 3.5mm audio male-to-male cable. The reason behind this decision is price, performance, and creating more abstraction between different internal systems in Essence of Music.

Audio input will be read in through the use of an Aluratek audio receiver. This is a commercial device that is capable of communicating with a Bluetooth transmitter from a distance of 10 meters. It connects to the system through a male 3.5 mm connection which requires a female-to-female coupler in order to connect to the rest of the system. This device was chosen over our previous choice through our research due to the fact that a lack of pin space on the microcontroller prevented us from fully implementing application communications. The ease of use in connecting the device to the system also aided in the late design changes that were made to the system overall.

4.1.4.2 Wired Input

For the wired input systems there are multiple inputs that have to be considered on top of the audio input. Since the user will only be able to control the pattern and the color schemes from the physical device itself, it is important that the device is able to seamlessly control these aspects as well. The device will take advantage of two of the digital input pins that the ATmega328p has in order to provide the user with a way to control the device. These will be connected to locations on the PCB which will allow for the soldering of buttons which will control the patterns.

The buttons will be located on the left side of the device when looking at it from the front, and will have two different colors. The front button will be used to control the pattern while the button closer to the back will alter the color schemes that are used in each of the patterns. There will be a total of 3 different patterns and 6 color schemes for the first two patterns. The last pattern does not use a color scheme due to how the pattern displays when reading in the audio signal.

Alongside the two digital inputs, there is also the ability of the user to route power to the microcontroller through the use of a power switch. This switch is connected to the 18650 batteries that power the microcontroller and setting the switch to the off position will prevent power from being routed to the microcontroller and also help conserve battery life.

On the opposite side of the device, the user will have access to two peripherals that allow the user to control the volume of the device. The first is a button that allows the user to shut off the speakers entirely without having to unplug the speakers from wall. The other peripheral is a knob that allows the user to control the volume of the device. This knob is the only way that the user will be able to control the volume of the device. These peripherals were originally included in the PCB of the speakers and our device makes use of these in order to simplify the overall design of the system.

4.1.5 PCB Design

The PCB is one of the key elements in getting our design working. It will hold much of the required circuitry for our system with regards to the microcontroller. Carefully designing this system will be an integral part of getting our system working correctly.

The design of the PCB will be done using the Freeware CadSoftEagle. EAGLE is a free piece of software that allows us to create circuit diagrams with specific values for named components. There are a range of components available from resistors to power system components most of which are available for us to use in the design of our system. There are also several other key features of the EAGLE software that will aid us in the creation of the PCB.

The first feature that EAGLE provides us with is the ability to create basic to complex circuit diagrams with the specific components of our choosing. This feature allows us to take various circuit components and design a circuit to fit our needs, whether it be a certain current flow to an output or a specific voltage range in another. The ability to create these circuit diagrams is key to getting the PCB designed and built.

The next main feature that EAGLE provides us with is component markets. These are online listings of parts that fit a certain description for the board that we design and plan to build. Furthermore, this system is also able to recommend alternative products should the exact device we need not be available. Coupling this with the system's ability to link to other key parts that are likely to be used with the selected component and we get a relatively secure way of acquiring components for the PCB.

Another major feature of the EAGLE software is the ability to create a virtual board using the circuit diagrams that we have designed. EAGLE is able to provide us with a virtual circuit board where it is easy to see how the different components will wire together and makes the testing process easy because you can see the wiring diagram for the board. The virtual design is also able to hold multiple test net classes such as power systems and can also show us various errors in the design that we have created. One example of an error that can be shown to us is the size of the component drill holes in the board which would prevent us from connecting all of the components correctly.

EAGLE is a very useful software that will provide us with several systems and features designed to make the design of the PCB much easier.

4.1.6 Casing Design

The casing for Essence of Music is a simple task and does not need much foreplanning. While there are many different materials in existence to construct the case, the Essence of Music team has decided to go with using polycarbonate plastics as the core material for the case. Polycarbonate plastics are quite durable materials that can endure light to mid-range impacts in case of common accidents. Polycarbonate plastic sheets are sold all over the place for a small price and come in various sizes of thickness. Due to the nature of Essence of Music needing to be portable, it is not likely that the polycarbonate plastic sheets will exceed a half an inch in thickness. The more probable outcome will be closer to a quarter or an eighth of an inch in thickness, but this cannot be fully determined until prototype testing commences. With the thinness of the width, it will not be too difficult to cut the sheets to meet the four cubic feet casing requirement and the polycarbonate plastic sheets will be adhered together using a market standard adhesive that can be easily purchased at any local store.

Polycarbonate plastic sheets come in various degrees of opaqueness. The type of opaqueness desired is somewhere between mildly translucent to completely transparent. Either will work, but in terms of an aesthetic factor, translucent is more desirable to hide the electronics and to make creating the LED grid more appealing to the user.

The LED grid will be placed in the middle of all the speakers. Underneath the actual outer casing much smaller pieces of polycarbonate plastics will be strung together in order to create the 32x16 LED grid, having one LED per grid box. If feasible, different paints may be looked into near development end to add for a more diverse aesthetic look to Essence of Music.

After considering the different options for producing a case for the project, the Essence of Music team decided on creating a wooden case to enclose all of the components. The primary reasoning is that the wood is cheap, easy to edit and create on the fly, it is stable, and should allow smooth audio quality from the speakers without interference.

4.2 Software Design

Essence of Music is a system that will require a decent amount of software in order for it to work properly. The microcontroller will require some level of programming in order to manipulate the L.E.D matrix.

4.2.1 Programming Languages

The basis of programming is deciding on the type of language that we wish to use when designing an application. However, since the Android is a desired target platform, it is reasonable to make selections based on compatibility with the device. Some languages are easier to use than others and the functions and coding style will vary from one language to another. When choosing the programming languages, we have to keep in mind: the platform we are designing for and the compatibility between the languages that we have chosen. The languages also have to be able to access various components of the device that we plan to use and have the ability to communicate with the microcontroller on Essence of Music.

Since Essence of Music will require using an application from a mobile device to operate, the coding of the application on the device will require that the programming language used enables the device to communicate clearly with Essence of Music. The language also has to be able to work on the intended device which will be an Android device initially. Expansion to other devices may follow, but Android devices will be the starting point of the project. As such, the programming language that the Essence of Music team will be working with is Java. Other languages are available for use on Android, but they are often more complex when implemented and require the use of the Android Native Development Kit in order to program on Android with them. Finally, Google recommends not using C or C++ due to the code being overly complex with no obvious improvements in performance [18]. JavaScript will also be used in the development of the application due to the languages access to the various aspects of the mobile device's main hardware features which include Camera, data files, accelerometer, and GPS.

4.2.2 Control Methodology

The application on its own will not be able to communicate with Essence of Music due to the fact that they are separate devices. As such, a method of communication will be

required in order to send instructions and data from one device to the other. From our research, Wi-Fi was a standard choice, but Bluetooth appeared to be a more reliable choice when factoring in the lack of an internet connection for the device.

The application will control the device through the use of Bluetooth communications with the microcontroller. The application will have a set of information in the form of the audio files and two sets of key data files in the form of display information and playback information. The audio files will be the music and sounds that the device wants to be played on the device. This will include the audio and all of the metadata available with the music. The audio will have to be converted from digital to analog while also preserving the digital signals due to Essence of Music needing both the analog and digital signals for both playback and LED manipulation. The application will have an integer value sent for the patterns and timer if more than one pattern is chosen by the user. If random is selected, an array of values will be set before hand in the application to account for the randomness which will then be sent to Essence of Music. The application will serve as a remote control for Essence of Music allowing it to be manipulated outside of the physical device.

4.2.3 Application Design

The phone application for Essence of Music allows the user to input their user setting in order to receive the optimal experience from the device. The user interface and overall design of the application will need to allow for the user to connect to Essence of Music, input various color and pattern options, allow the user to control the volume of Essence of Music, and be able to send music from the phone application to Essence of Music.

4.2.3.1 User Interface

One of the most important factors for users that use an application on any device is how they find the user interface. A simple design would not allow for the level of customization that we desire for the user to have. However, having an overly complicated interface would be off putting as well as an interface that is too difficult to use would prevent new users from taking to the application. The goal of the user interface is to find a clear middle ground that provides the user with an easy-to-use

design that also provides a large amount of customization on the limited screens provided.

The user interface of the device will be rather simple. The user will be able to see a few options on the opening page which will be linked to the various controls that they will have over Essence of Music. The options that the user will be able to change at first will be Patterns, LED Colors, Songs, Playlists, and Device Syncing. Of the options available, Device Syncing is the most important one. This option takes into account the fact that the devices will be using Bluetooth. An example image of the UI home page can be seen Figure 4-8.

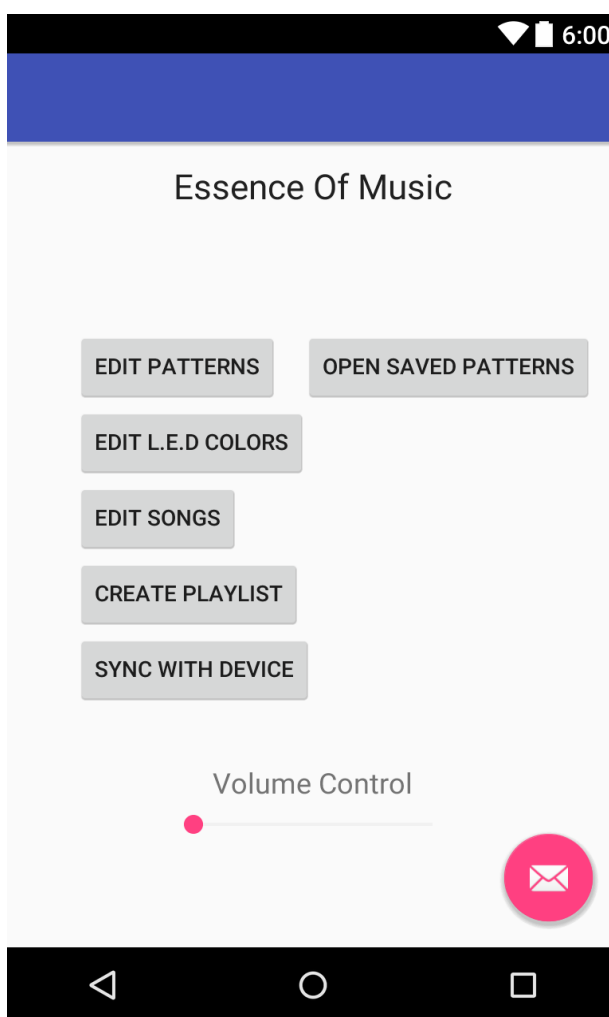

Figure 4-8 Example Homepage to Application

The UI design of the homepage of the application is designed to let the user see the majority of the options that are available to them. The user will have the ability to

access all of the main functions of Essence of Music without having to enter another screen. Figure 4-8 shows the key buttons that will be on the main page but the layout and design will be greatly different from the current example. Another key feature of the UI will be the ability to modify the volume of Essence of Music through the use of a slider on every screen. This feature is similar to how many phones allow the user to modify the various volume settings with a certain set of buttons regardless of where the user is on the interface.

Most of the linked screens will revolve around a list and the user selecting a specific item on the list and then using a button to make changes to a particular aspect of the selection. Figure 4-9 shows an example of this.

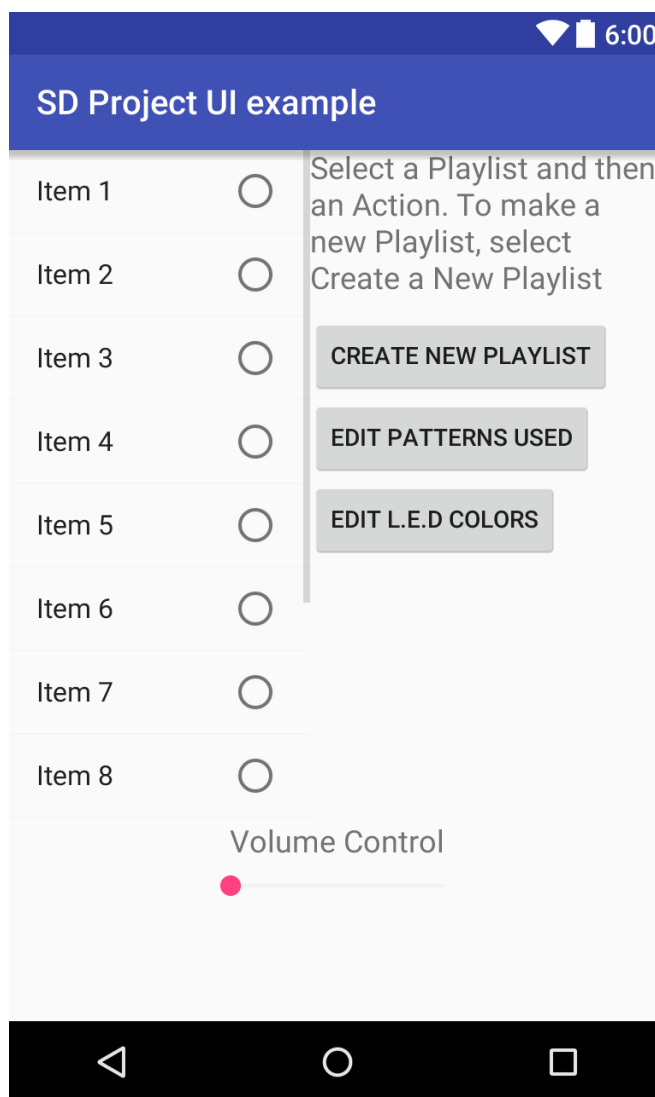

Figure 4-9 Example UI for Application

Figure 4-9 shows an example of the Playlist editing screen that the user can access from the homepage. The user is able to choose one of the items on the list and then select an action to perform on the device. In this case, the Playlists page links to the specific patterns and LED colors that are used with each playlist. The user will be able to choose the patterns and LED colors that are used with each playlist. This will allow the user to save multiple customizations and name them allowing for quick access to their desired options. Similar to the layout in Figure 4-14 the layout design of these screens will change and currently only shows the key items and features that will be featured on the screens.

4.2.3.2 Software Diagrams

The following images are key diagrams that show the state of the application and the main classes that will be included in the system as a whole. Each of the diagrams will feature key information related to the creation of the software as a whole.

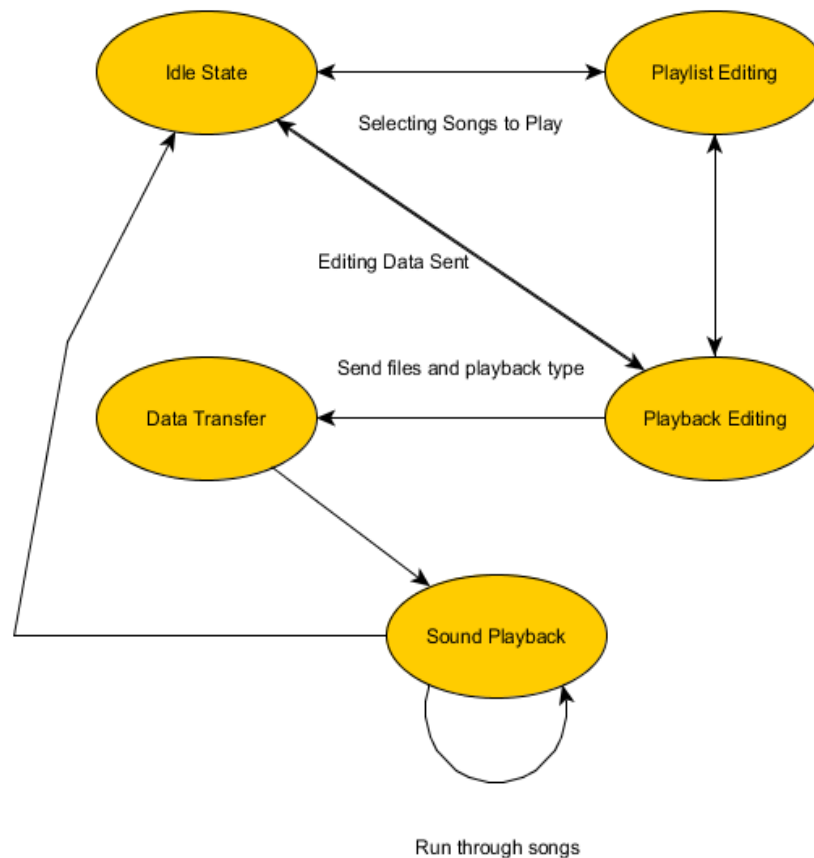

Figure 4-10 Class Diagram of Application

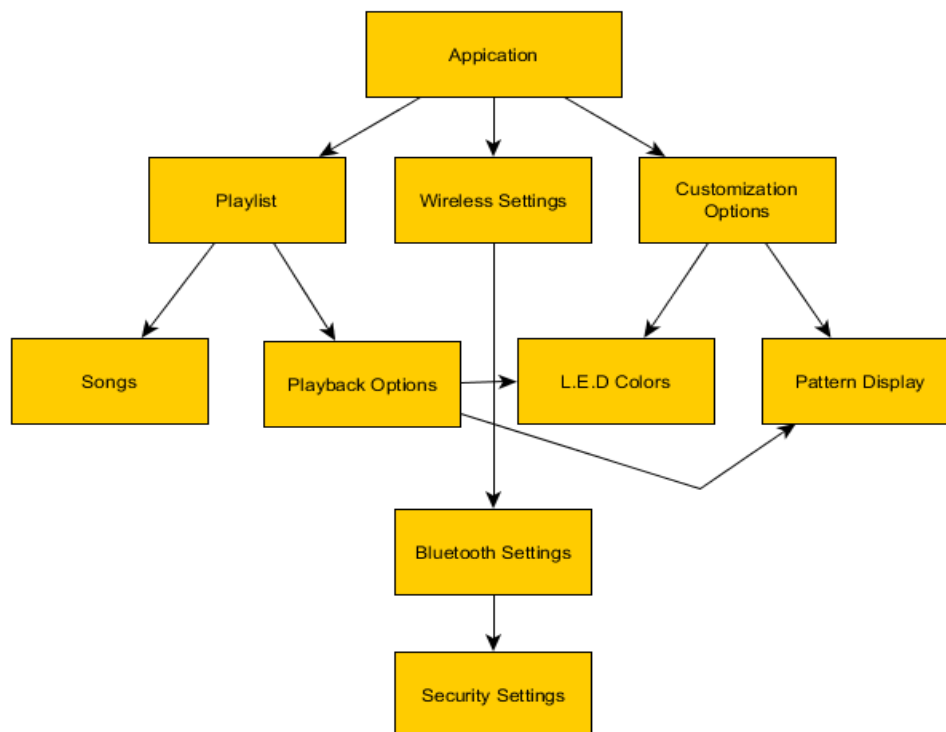

Figure 4-11 Application Interactions with Hardware

There are some key facts that can be found in the diagrams. First of all, the State Diagram shows the main states that the application itself will be in. The idle state is when the application is not sending any data out and the user just stays on the main home screen. There should be no sending or receiving of data with the exception of a system notification in the form of battery level or playlist ending without the LOOP feature active.

The next possible states for the application are the two levels of editing. The first level of editing is the Playlist editing. Here, the user is able to create and modify playlists which will be combinations of audio files that are stored on the system. This will include adding and removing files from the existing playlists and adding new playlists that have files included upon creation. A playlist can have no audio files in the list but this will prevent the user from moving onto the next step of the editing phase which is the LED editing.

The second editing phase is transitioned into from the Playback editing state. The application will automatically pull this screen up when the user creates a playlist that has at least one audio file in the set. This will allow the user to create a playlist and make changes to the pattern without losing track of the patterns that have been created. The user will be able to decide from this screen if they want to return to the

playlists editing screen or if they want to start sending the data to Essence of Music so the system can start playing back the files. The main features available in this state are the ability to select the pattern that the user wants to apply during a song and the possible LED light colors that the user wants to use for the patterns. The user can decide if they want to apply the pattern and color choices to a single song, multiple songs, or all of the songs in a playlist through the use of the multiple-select list on the device. This allows for greater flexibility in making choices related to customization which eases the burden on users.

The next state is the Data Transfer state. Ideally, this state should only be in effect for a short amount of time as it is the state when the application is sending key information to the Microcontroller regarding the audio files to play and the LED configurations to use. The transfer of data will occur over Bluetooth and will also consist of converting the analog signals to digital signals to allow for transfer over Bluetooth. The microcontroller will then decode the digital signals while keeping a working copy for use with the LED configuration signals that it receives.

The final main active state of the system is the Audio Playback state. The application in particular will be able to see the songs that are being played and the active playlist. From here, the user can return to the homepage while letting Essence of Music play the files, or the user can stay on the playback page and move throughout the playlist while maintaining the customizations on each song. Users will also be able to see the timestamps of the audio files and move to specific times on each song and continue playing from there. If the user returns to the homepage, there will be an option to go to the active playlist for both editing and playlist manipulation. If the user decides to edit the active playlist and push the changes to Essence of Music, the device will experience a hiccup in playback as it updates the active playlist with the new customizations.

With regards to the class diagram, some of the key items are not shown in the diagram which includes the key variables that are included with each class. Of the classes that are shown, the ones that have major variables are: the songs, Playback Options, Pattern Display, and LED Colors. In terms of naming, the Songs class is the most literal of the group.

The Songs class will include various information about the audio files that are being sent to Essence of Music. It will have the audio file and the metadata extracted into individual variables in order to make the data extraction easier. Songs will attempt to extract: the artist, the song title, the album name, the album number, the BPM, the

genre, the affiliated artist, the composer, and the performer. These are the key variables that will be associated with the class and will aid in the metadata display pattern of Essence of Music.

Playback Options will be associated with the playlist that it is under, and will also include the Pattern Display and the LED colors as components. Playback Options will be used as a single unifying class that holds the variables of the customization.

Customization will be handled by the Pattern Display and LED colors classes. The Pattern Display class will have the various pattern values stored as integers and marked with a number from 0 to x where x is the number of patterns available. Patterns will be displayed in the order of the integers and patterns that share the same integer values will be combined for display. The LED colors class will be modified depending on the level of control that the Essence of Music team wants to be able to give the users. With the highest level of control, the LED color class will have 256 objects with two sets of RGB values associated with each one. The first value will be the starting value and the second will be the ending value which gives the user the ability to change colors, even if it is only in a single direction. The color setting would be done by having the user utilize an interface that shows 256 square that represent the LED lights. They can then choose areas of the LED grid to modify and then select the colors that they want to use through the use of a color pallet. The user will then select a starting node and then an ending node for the LED lights to pass through. If time allows, the ability to select more than 2 nodes (allowing for intermediate nodes) will be implemented allowing users to have the LED display run through more than a linear set of colors.

5.0 Design Constraints

As with any product ever designed, there are always design constraints that need to be taken into consideration. Fortunately for the Essence of Music team, the design and goals of Essence of Music do not pose too many constraints in terms of possibilities in existence that can place constraints on a product. Different kinds of constraints that are in effect towards the device include various economic and time constraints, given various factors in development and financial aspects. Health and safety is always a concern for any product designed for human usage. Lastly, manufacturability and sustainability constraints must also be evaluated in order to guarantee user and production satisfaction and feasibility.

5.1 Economic and Time Constraints

Essence of Music is a project that has a medium level of design complexity due to the amount of customization that the Essence of Music team is planning to provide to the users. The cost of the device is less of an issue than the amount of time that there is to actually create the device and program everything. Costs are mitigated by the low cost of the components and the team's ability to buy many of them in bulk for a lower cost of parts overall. The costliest systems of the device are the speaker system followed by the LED grid and then the power system. Costs of using particular components and brand names appear to be small at this point in time and will not have that much of an impact on the overall true cost.

Monetary costs are one thing, but the time constraints are another. Programming can begin as early as when the basic user evaluations are completed, but construction of the device can be an issue. Parts will take some time to ship and if the parts are not the ones that are needed, it will take time to reorder parts and get them to ship. This is coupled with the actual time that it takes to construct the device leading to a sinkhole of time. Physical construction of some of the parts can also take a while. Soldering the LED lights together in a grid pattern will take a while in and of itself, and constructing the speaker systems will also take some time. There are also multiple prototype tests that will take some time to complete. The battery life test, for example, will ideally take around 4-6 hours for each run as the team tries to calibrate the system to be able to enhance the active time of Essence of Music.

Programming is something that could be started as soon as the user evaluations are completed, but the actual programming itself could take a while due to the level of complexity that is desired to give users with regards to customization. There will be a decent level of complexity in the programs for the application especially with regards to the management of LED colors and the ability to customize the light patterns. These will be the most time consuming parts of creating the program with just as much, if not more time being allocated for the troubleshooting of the programs. Many of these issues will also be applied to the microcontroller with regards to the design of patterns.

Extending on programming time constraints is the use of user evaluations in helping to design the application. This process could take a while since users need to be given a survey to complete and some may even be given a base prototype to use and evaluate before the actual design is produced. This could turn into another time sink, but user evaluations and surveys are something that the Essence of Music team will not have to repeat for design after completion. An end of production user study could be performed, but this would be purely for enhancing the device after the final prototype is created.

5.2 Manufacturability and Sustainability Constraints

Manufacturability and sustainability constraints that pertain to Essence of Music are not uncommon constraints with any particular product. Constraints in this category that need to be taken into consideration are is the lifetime and durability of Essence of Music and the transportability aspect of the device. Factors that affect these constraints consist of the size and weight of individual components, the way energy is stored in the battery, and the actual material used to encase the device itself.

5.2.1 Expected Lifetime and Durability

The Essence of Music device has an expected lifetime of around seven years with some level of maintenance. This is due to the fact that Essence of Music is designed to be a transportable device but can also be a device that one may leave in place for use in a single location. If the device is left in a single location, the amount of maintenance that needs to be given to the device is rather low. The biggest issue with this type of storage would be maintaining the battery life of the device through charging and low energy storing. Low energy storing is used because the battery life of a device

decreases with the amount of energy that is left in the battery during storage. For example, storing a device with a rechargeable battery at 100% power will lead it to have a lifetime deterioration of about 10% to about 90% of its maximum lifespan.

In the case that the device is transported regularly, the expected lifetime of the device will decrease due to general wear and tear. The device will be rather easy to transport, but the material that it is made of will greatly affect how long the device lasts. The current design allows for Essence of Music to be rather easy to transport, but the level of durability is something that can be given strong estimates for. As such, there is not any planned way to reliably test the durability of the device with regards to impact and general tumbling. However, the device is designed to have a certain degree of water-resistance which is something that can be tested and gain a measure of easily. Essence of Music is expected to be able to endure light drizzles and spilt liquids. Any phenomena stronger than this, such as a rain storm or complete submersion is not something that Essence of Music is expected to be able to endure.

5.2.2 Transportability

Essence of Music needs to have a certain degree of portability in order for it to meet the basic needs of the system as an entertainment tool. The device needs to have dimensions less than four cubic feet in size which would allow for easy transportability when packaged. Ideally the finished product will be under five pounds, with perhaps a little more to accommodate the speaker system size and weight. These self-imposed restrictions on size and weight make it so that the entire device is easy to move around and set up, while also being a decently powerful system that can play back audio files.

Since the size of the device is restricted, the various components are also restricted in size as well. There are five main components planned for Essence of Music: the microcontroller, the LED light grid (32x16), and three speakers: Bass, Stereo and Tweeter. Combined, the five components need to lay in a volume of about four cubic feet meaning that none of the components should be larger than 1.6 feet long, wide or high. Ideally we would want the devices to be able to fill up about one-fifth of the total volume that is suggested, with some modifications depending on the type of component.

The LED grid will be larger than the microcontroller but smaller overall than the speakers. The larger items will be the speaker systems which need to be able to produce sounds in the desired decibel range. Designing the speaker system to fit in the

range should not be difficult if the myriad speaker systems that are rather small and can produce loud sounds are taken into account, such as some computer external speakers. The issue comes in maintaining a total size less than four cubic feet with all of the components.

The weight is another item that may cause issues during the building process. Aside from the speakers, none of the components are particularly heavy, but the weights of multiple parts can add up quickly. Choosing parts that are durable and lightweight will be key when constructing the speaker systems which will also allow for ease of transport of the device.

5.3 Health and Safety Constraints

Health and safety are factors that must always be taken into consideration when designing/developing a product for human use. Fortunately, Essence of Music does not have many factors that make it dangerous to people outside common factors that any common household item may have. Though the number of dangerous factors are limited, this does not make them any less serious. Factors that need to be taken into consideration for health and safety are sound levels and brightness settings. Essence of Music needs to have a powerful audio and visual qualities, these should not be at the expense of the user.

5.3.1 Sound Levels

Essence of Music is an audio playback device and as such is subject to constraints regarding human hearing safety and environmental sound pollution. With regards to human hearing, damage occurs with prolonged exposure to decibel levels at or above 85 dB [18]. One of the goals of the device is for it to be used at events such as parties, so a sound level of about 95 dB is the maximum loudness that is desired to be achieved. However, since there is a possibility of Noise-Induced Hearing Loss, a warning will have to be given to the user and on the device regarding this phenomenon.

While the loud sounds can lead to NIHL, another factor that must be kept in mind with the noise levels is noise pollution. Noise pollution is an issue that affects millions of lives daily and is attributed to loud noises such as the ones that Essence of Music is designed to produce. The EPA has made it known that noise pollution is an issue that

has to be addressed. There are also several health issues that are related to noise pollution including, but not limited to: stress related illnesses, high blood pressure, speech interference, hearing loss, sleep disruption, and loss of productivity [19]. Again, the users of the device need to be notified of noise pollution when using the device. This can be achieved through either a warning on the application that they use to interact with Essence of Music or through a physical warning that is placed on Essence of Music itself to warn others of both NIHL and noise pollution.

5.3.2 Brightness Settings

Essence of Music is a device that emits light through the use of LEDs. The light that is emitted can vary in brightness depending on the type of display that the user wants to show. However, there can be some slight issues with safety regarding extended exposure to bright light sources. The most prominent possibility is retinal damage to the user. This can occur when the user's retinas are exposed to a bright light source for an extended period of time [20]. Another possible side effect is age-related macular degeneration. This is a natural phenomenon, but exposure to blue lights can increase the risk of developing this issue [21]. Taking these into consideration, Essence of Music should include a health and safety warning regarding brightness and blue light exposure. Warnings will be used instead of placing limitations on the LED brightness settings due to the fact that Essence of Music relies on the LEDs for display and requires a certain level of brightness to do so. In a dark area, the LEDs need to be bright enough for guests and others to see from a distance, especially since one of the display options is to show the metadata of the audio file that is being played. Further restrictions on the LED brightness would cause Essence of Music to be incapable of fulfilling its primary role.

5.4 Hardware Constraints

There are also constraints to consider regarding some of the choices of hardware that the Essence of Music will be implementing. Two primary hardware constraints come to mind.

The first of these hardware constraints is the constraint of our microcontroller - the Atmega328P. Upon trying to process the analog signal, we noticed a lack of pins on the device. There are five analog input pins, however they are all used in the process of doing a high-speed analog to digital conversion. Because of this hardware constraint, it

is not possible to do complex mathematical calculations while also reading in the analog signal from the music.

The other big hardware constraint is the durability and energy storage potential of batteries. Because batteries cannot hold an infinite amount of energy, we have to account for that in our system with regards to how much power each of the components are drawing. Because the speaker amplifier and the LED grid require large amounts of power relative to the signal amplifier and the MCU, those components will be using wall outlet power to meet their power constraint.

6.0 Prototype Construction

Upon receiving all required materials for Essence of Music, it is important to get a functional prototype of the device in order to see the practical aspects of the design process. Everything until the prototype is a calculated estimation based on standard science and engineering practices, however often times prototypes do not necessarily function properly immediately. The prototyping part of the creation process is important to see how engineering predictions come into reality. For Essence of Music's final prototype, it will have all of the working functionality stated during the requirements and specifications. The final working prototype will include Bluetooth receiving protocols, controlling for the light display, functional speakers that produce an output loud enough for a room environment, and a combination of power from both the wall outlet and internal batteries. All of this will be held together within a proportionate wooden case meeting Essence of Music's dimension and weight requirements.

6.1 Hardware Construction

Although there is more technical documentation of the electronic components and software aspect of the Design, the hardware construction of the case is very important. One of the design requirements is to have a volume of the box that is less than four square meters. Because of this, each side of the box (assuming a square setup) will be a length up to 1.587 feet in length, height, and width.

The plan of hardware construction is to set up this cube shaped chassis that will hold all of the electronics on the inside while having the midrange and high frequency speakers on top of the device, while the bass speaker will be located on the bottom of

the device for better sound resonance throughout the room during operation. There will also be an on/ off switch on the outside of the device for better life/ battery control, there will be a volume knob for volume control on the outside, and there will also be an auxiliary input for audio input. Last but not least, the last device that must be visible from outside the device is the LED light show.

6.1.1 Power Unit Construction

Construction of the power unit for Essence of Music will consist of wiring and setting up the Panasonic 18650 batteries into a single casing where they can all be charged conveniently from the outside of the chassis. As discussed in section 4.1.1, the Essence of Music will contain six battery cells. Each of the batteries will be paired in series in order to give an output voltage of 7.4 volts nominal to 8.4 volts maximum. This output voltage will be stepped down using a 7805 linear voltage regulator circuit. The power aspect is an integral aspect of Essence of Music - so every component needs to be unit tested to insure proper operation Voltages and Powers. For testing purposes, Essence of Music's components will all be tested using a 5V DC signal generator. After ensuring proper operation, the team will test the output Voltage level from the battery, and then wire the components to the battery. The prototyping for the Speaker and LED matrix power is relatively straightforward as all it requires is hooking up the necessary power adapters into a wall outlet. As was stated in the Design section, testing power for the audio signal amplifier will be successfully prototyped using 9 Volt batteries.

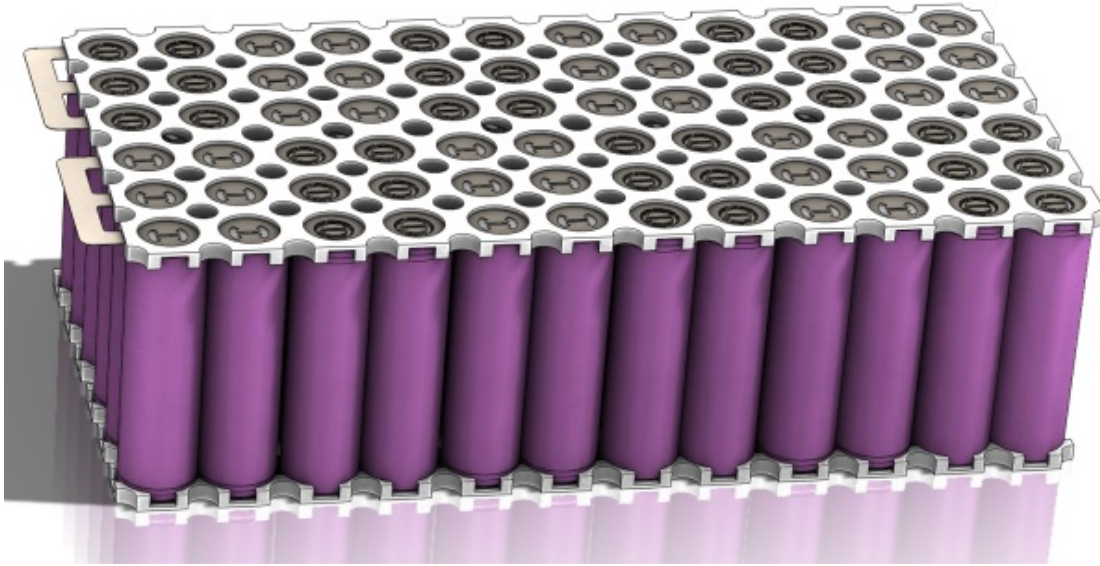

Figure 6-1 [14] Image of Massive 18650 Energy Storage

Figure 6-1 shows an example of a larger lithium ion battery pack. Many components will be wired to Essence of Music battery pack that is created, so it is important to ensure that the wires connecting the lithium ion cells together are wide enough to ensure that no components are being overheated or shorted.



Figure 6-2 [25] Example of Heat Shrink Tubing to be Implemented

During construction the system will also make use of heat shrink for wiring where needed to prevent accidental shorts throughout the system - this is especially important in Essence of Music's design because the cables on the inside of the chassis are prone to moving around as the project is transported from location to location.

6.1.2 Speaker Construction

Speaker construction should be relatively simple. Once the chassis is created, there needs to be room for speakers to be implemented. As stated in section 6.1, the project box that everything is contained in is expected to be a maximum of four cubic feet, so that gives us roughly a 1.5 foot by 1.5-foot area on top for the two midrange speakers, and the same area on bottom for our base speaker. Installation should be quite easy, once the chassis is properly setup and stable, all that needs to be done is to draw lines on the chassis for the size of the circular holes that are required for the woofers and bass. Once the sizing for the woofers is setup properly, the team will need to saw holes in the top and bottom of the box in order to fit the woofers and base into the system. Once the positions are setup for the speakers, Velcro will be used to secure the speakers in place while not interfering with music quality.

6.1.3 Bluetooth Construction

The construction of the Bluetooth component of the system is simplified due to having a complete Bluetooth audio receiver being included in the design. Furthermore, the system has had to abandon the use of an application at this point due to some issues with the original receiver and the hardware that is being used. This Bluetooth receiver is also a result of not having the appropriate level of connection with the hardware. Before using the Aluratek receiver, a separate device was being used but experienced a catastrophic failure that prevented the device from being used in the design.

6.1.4 PCB and LED Construction

Over the last decade, more and more PCB manufacturers have popped onto the market which has created a system that is easier for engineers and developers to create their products in a faster, easier way. From looking around for what Essence of Music's needs are, PCBWay appears to be able to satisfy the team's needs, having

very few issues with construction and also providing a speedy construction and inspection time.

The team will setup a .gerber file using the Eagle software that will have final PCB construction designed. This will include all of the modules required to be in one final piece in order for final development. The final board received included a missing wire between a voltage regulator and resistors which had to be fixed by soldering a wire connecting the two nodes.

The LED construction is similar to that of the Bluetooth receiver. The LED matrix that we acquired from Adafruit is able to connect to the system through the use of a ribbon cable which can also be extended with jumper cables.

6.1.5 Case Frame

The case frame for the project will be made out of Broder brand wood from Ikea. The wood is light and easy to cut which helps in the weight and size requirements of the device. The decision to move away from a translucent material was due to the ease of access and also the fact that all of the electronics within the device would be visible, even if only lightly. The wood on the other hand can also be painted various colors in order to provide an extra layer of customization to the user.

The case has dimensions of 11x7x7 inches (rounded up to the nearest inch) which is within our size requirements. Furthermore, the device as a whole has a weight less than 5 pounds which is the other physical requirement that had to be met.

6.2 Software Development

Software development need to adhere to industry coding standards. This applies to both the android phone application development and the microcontroller C programming for the LED grid.

6.2.1 Microcontroller Coding

During prototyping construction/development the ATmega328P will require C code to tell it how to interpret the analog signal from the Bluetooth receiver. Because of our configuration setup, it will be receiving an analog signal on analog input 0 that will be interpreted as a 10-bit number by the microcontroller. This input will be processed

every second during operation and it will have output code that controls the output to the digital output pin where the LED strip is connected. An example of said code would take the loudness of the music at any given time and control the brightness of the LED system. Another alternative would be to create an algorithm that notices beats to the music and would change every four or so beats to the song. There are many different profiles that can be created and will be discussed further during code implementation. This will be much easier to see what gives the best results as the system is being programmed – and after it is already operational.

7.0 Prototype Testing

Essence of Music, as with any other device meant to be used, needs to undergo prototype testing. Rarely in the world does something go perfectly well first time around and every possible factor gets accounted for. The various hardware components such as appropriate power is supplied to each component in the system, the speakers will need to be tested for appropriate audio levels and performance, the LED grid will need to be tested extensively to get each possible visual variation the user requests without issue, and that all software written is performing all desired tasks.

7.1 Hardware

Testing the hardware of the system will be consisting a lot of unit testing of each of the different hardware components, and then slowly combing them together into one bigger system. There are many different aspects of the system that must all work on their own. The power system unit testing will be done with the iMax B6 for charging and discharging the batteries as well as measuring their true capacity instead of their marketed capacity - there is known to be many fake 18650 batteries on the market. Unit testing for speakers will be done by testing the speakers in a standard fashion.

7.1.1 Power System

For any system that works on a rechargeable battery, the ability of the battery to store a charge and provide power to the system is of utmost importance. The power system of Essence of Music needs to be able to provide power on a certain scale for a set

amount of time in order for it to perform its duties as a product designed to be brought around or used as a stationary display device.

The playback device should be able to run on a battery for a certain amount of time. This amount of time would be between 5 hours and 7 hours due the devices possible use at a party type venue, be it large or small. This can be easily tested by fully charging the battery system and then allowing it to sit while running and measuring the time it takes the battery to fully drain (or drain to a certain amount). Measuring of the battery life could be done by either incorporating a system into the light display that shows system data or by using an external power indicator.

In order to gauge the minimum amount of time that the system would be able to operate for, one simple method would be to program all of the system settings to operate at the maximum capacity for the unspecified amount of time. Systems that can be active include: LED lighting where all of the 512 LEDs will be active at the same time or have the 512 LEDs flashing on and off for short intervals, the wireless capabilities having either Wi-Fi or Bluetooth enabled for the duration of the system's operation, and audio playback where the decibel levels would be set to the maximum levels suitable for a recreational venue. The overall would be a success if the system can reach 5 hours without having to charge or receive external power and still operate at full capacity. The test will fail if either the sound quality drops or the LEDs start to dim before the system reaches the 15-20% battery level. This test succeeding means that the device is able to maintain operations for the specified amount of time lending to its portability. The implemented hardwired power for the LED array and the speakers allowed testing to proceed smoothly and the duration of playback for the device withstood much longer than our initial requirements.

7.1.2 Speaker System

Another key aspect of Essence of Music is the sound system that plays back the audio files that are stored on the Android device. Essence of Music needs to be able to playback the audio files while maintaining two key qualities, sound volume and quality. More specifically, Essence of Music needs to be able to playback the audio files at the user's desired volume levels, whether they be low or high, while maintaining a sound quality that the user can relate back to their existing experiences with the sounds or music.

After prototype testing, the system far exceeded our expectations in terms of audio playback. The quality is relatively high and sounds nice in a general sense. There is no power issue because of the wall power. The volume could indeed be set relatively loud and could be heard across a smallish building or house. Unfortunately, no precise decibel level was able to be measured, however we felt the loudness of the system far exceeded what was set in our design requirements.

7.1.2.1 Decibel Levels

The playback device decibel level testing can be done by measuring the total decibels recorded in a mostly soundproof room using an accurate sound level measuring device. The first test is to determine whether or not the device can produce a sound with decibel levels that can be heard over a loud party. The sound produced by the device would have to measure up to the possible sound levels found in small to large scale parties where the playback device is intended to be used. As such, the device would have to produce a decibel level of approximately 95 dB. This is approximately the same sound level that is produced by a passing train's whistle which should be appropriate for the device. Furthermore, this sound level of 95dB is also below the threshold for which sustained exposure could cause lasting damage to one's hearing. The test succeeds if the value of 95 dB is reached with less than a 2dB error range. The test fails if 95 dB is not reached or if the device extends past the target sound level by more than 3dB. While the device may be able to produce sound levels greater than 95dB, it needs to be able to produce about 95 dB when the correct adjustments are made. This test succeeding means that the device is able to produce a loud enough sound that can be heard by guests attending a large party venue.

A second test would also have to be conducted in order to determine whether or not the device can produce respectable levels of sound. A goal of 95 decibels would allow the device to be heard in its appropriate setting, but playing loud noises is not the only function of the device. Alongside being able to play back sounds at high decibels. The device would also have to be able to produce sounds along a range of volumes from 30 dB which is about the same as a whisper in a library to 95 dB which is the sound level that being aimed for to reach with the device [26]. The test would be conducted in a mostly soundproof room and start with the device put on the lowest possible sound level setting. The levels would be measured and the volume increased. The device aims to use a knob to change the volume so certain degrees of rotation would be measured and the increase in volume measured. The changes would be constant in

order to record the appropriate sound level values that are produced. The test succeeds if the device is able to produce a useable range of sound levels between 30 dB and 95 dB without any major skipping issues. The test fails if the device is unable to produce the range of sounds without making a jump of more than 10 dB between any major rotation intervals. This test succeeding means that the device is able to produce a wide variety of sound volumes that users can tweak to suit their needs.

Unfortunately, due to accessibility constraints, we were not able to perform this test, and felt the test unnecessary as the loudness of the device reclined at suitable levels.

7.1.2.2 Sound Clarity

The sound clarity is one of the most important qualities that Essence of Music will have and as such it will need to be tested thoroughly. However, this testing will revolve around the perceptions of other people as opposed to the Essence of Music team using the device to test the clarity. This is not to say that a mechanical test will not be performed, but that the opinions and results of having other people listen to the device and the sounds that it produces is of the utmost importance regarding this quality.

In order to test this quality, the Essence of Music team will utilize a mostly soundproof room and ask several people, students or otherwise, who have listened to a particular song very closely for a while. This is to allow the testers to know the song or sounds that are playing and whether the quality of the sounds produced is of adequate level. Each test participant will then fill out a survey which asks them to rank the types of sounds that they heard and asks them to compare the song on the playback device and the song as they know it. Questions will ask about the quality of the sound, whether they found the music on the device to be reproduced in a way similar to that of their own devices, and several others. The test succeeds if the participants found the music reproduction to be pleasant or true to their own experience of the songs or better. The test fails if the participants found that the music was not reproduced correctly with major differences in the way that the various sounds are handled. Passing this test means that the device has the capacity to reproduce music in a way that is pleasing to most users. Failing this test means that the device is unable to work with the various sounds that are produced in an aesthetically pleasing way. However, failing this test on a small scale simply requires more testing in the same way that passing the test in a small scale could require more testing.

A mechanical test will also be performed in order to check to see how similar the music reproduction is to other devices. Taking a sound recording of various sounds utilizing different types of instruments and natural sounds, the sound recording from a brand name product and Essence of Music will be compared with the differences between the sound graphs being the determining factor. The test will succeed if the playback device is able to reproduce a sound graph similar to that of the brand name product. The test fails if the sounds graphs are radically different from each other. A success in this test means that the device has the ability to reproduce sounds at a quality level similar to that of brand name products. A failure in this test means that more fine tuning of the speakers and sound filtering will be required.

7.1.3 LED Array System

The LED array system will be individually tested using Arduino board to ensure proper operation on a standalone scale. There is even code snippets online that allow the Essence of Music team to test a few different lighting settings directly after implementing them into the microcontroller. Once we have tested the LED light strip using a breadboard, standard power supply from the engineering labs, and the Arduino, it is then time to do more unit testing with more aspects of the project operating at the same time. For example after the LED strip is functioning with the DC power from the lab power supply, we will then test the system with the LED strip being powered by our battery system. Once that is functioning properly, it will then be tested with the power system being connected to both the Arduino board as well as the LED strip. From that point forward it is only a matter of adding a few more components until the system works all as one full system.

7.1.3.1 Lightshow Patterns

Visually, Essence of Music relies on the L.E.D grid in order to provide the user with a visual representation of the patterns and L.E.D colors. The patterns in particular are a source of examination due to having a rather high level of complexity in determining how the L.E.D grid lights up.

The lightshow patterns are the core of the playback device in terms of what the average user will be focusing on aside from the music that is emitted from the device.

As such, the ability of the device to display the correct patterns using the LEDs will have to be tested thoroughly.

The L.E.D matrix was tested in two main ways. The first method involves lighting up all of the lights in succession followed by lighting up all of the lights simultaneously. The second test involves testing the patterns on the matrix for extended periods of time.

The first test went smoothly with all of the L.E.Ds lighting up as expected. There were no lights dimming or flashing out of color. When under optimal conditions. However, some issues arose under certain conditions. The L.E.D matrix had issues displaying the correct colors when it was unplugged from the wall, leading to the decision to include wall power as an option.

The second test involved the running of all of the patterns from the microcontroller. This test completed successfully as each of the patterns was able to run for several hours continuously.

7.2 Software

Software is one of the more time consuming components of a device or system to perform testing on. There are issues such as bugs that need to be found through the use of exhaustive test cases designed to sweep through all of the potential options a program might have. These tests need to be able to identify where in the system an error occur and allow the design team a way to modify the material in order to reach a working model. However, the tests do not stop there. Being able to withstand tests on an exhaustive scale is one aspect of software, but when a user interface is introduced to the system, it needs to be evaluated as well. The user interface is the part of an application that users will be interacting with the most and will need to be designed in such a way that the users will find the application to be easy to use while offering the customizations that they are expecting.

7.2.1 Exhaustive Pattern Testing

The exhaustive pattern testing was performed in order to check that the pattern coding did not have memory leaks as well as to make sure that the code can run continuously without issue. This was also a method of making sure that the system is able to change the patterns and color schemes at a decent pace. The initial coding method that was used changed the light patterns much too quickly, and as such, an artificial delay was added in order to prevent the system from creating an obvious delay in the display.

8.0 Administrative Content

Administrative content is resources that the Essence of Music team has used to plan and organize different aspects of the development lifecycle of the project. This includes all content that refers to budgeting and finance, milestones and deadlines, and general group organization.

8.1 Budget and Finance

The below table gives a good description of the products that are to be bought in order to configure Essence of Music. Prices and suppliers are not guaranteed because products have not already been ordered and prices fluctuate over time.

Item Name	Supplier	Total Cost (USD)
17 Pcs x 28 Pin DIP IC Sockets Adaptor Solder Type Socket	Saim's Store	\$4.47
uxcell® 10 Pcs Faux Leather Housing T Type Clip Connector for 9V Battery	VNDEFUL	\$4.78
Aluratek iStream audio receiver	Aluratek	\$29.99
AmazonBasics 9 Volt Everyday Alkaline Batteries (8-Pack)	Amazon.com LLC	\$9.99
Battery Holders, Clips & Contacts PCB PLSTIC BATT HLDR SMT 2 CELLS	Lonesome Vapors	\$7.24
50 Pcs 16.000MHz AT49S 20PF DIP Quartz Crystal Oscillator	Find4Fix (CN Direct Shipping)	\$3.00
Addicore 5V 1.5A Positive Voltage Regulator L7805CV in Antistatic Foam (5pcs)	Addicore	\$5.95
2 of LG 18650HE2 2500mAh Rechargeable Batteries, 2-Pieces	unicshop	\$12.85
4-pack NEW Atmega328p-pu Chip w/ Arduino UNO Bootloader	12V application	\$17.49
Arduino Uno	Adafruit Industries	\$25.00
Audio Splitter	Radio Shack	\$14.99
3.5mm Stereo Coupler	Radio Shack	\$5.49
Push Buttons	Skycraft	\$3.00
On/Off switch	Amico	\$4.52
Broder Birchwood	IKEA	\$10.00
Various Resistors/ Capacitors	UCF Senior Design Lab	\$0.00
TL082	Radio Shack	\$2.50
PCB Production (5x) - Expedited shipping	PCBWay	\$84.00
Velcro	Skycraft	\$5.36
Zipties	Self ownted	\$0.00
	Complete Total:	\$250.62

Table 8-1 Parts List and Cost

8.2 Milestones and Deadlines

There are specific milestones and deadlines that need to be met in order to ensure that the final product comes out in prime condition and the resulting product does not seem rushed. The following table discusses particular timelines that are expected to be followed.

Phase	Expected Timeline
Research	August-October
Design	September-November
Preliminary Documentation	October-December
Parts Acquisition	November-February
Construction	December-March / May-June
Prototyping	January-May / June
Final Documentation	March-May / July-August

Table 8-2 Milestones to be Met

The milestones can be divided into two sets. The first set of milestones are the initial research phase where information about the system to be built was performed. The system design was also performed during this period.

The second set of milestones includes the design and creation of the system itself. During this time, the creation of the system is performed through the acquisition of the PCB and other primary components. Prototyping and testing were completed in this session.

Each of the sessions lasted approximately 4 months, however the second session had an unexpected delay that pushed project development back to be completed 3 months later. This was due to the PCB component of the system being incomplete at a critical point in time. As such, an extension was made and the second session was repeated to ensure a certain level of quality was kept within the creation of the project.

8.3 Group Organization

There were a few group protocols that we followed in order to keep everyone in the group on the same page and level of understanding. The primary method of communication for contacting the whole group at any given time was Facebook messenger. After early discussion, the group agreed upon the idea that some form of instant messaging protocol would be the easiest way to contact everyone at the same time, and Facebook was a very easy means of communication. Skype group chat was utilized as well during times when text did not provide enough clarity between ideas from the Essence of Music team. To keep formal reports on the same page and make sure that multiple people were not covering the same topic at the same time, a Google document was created early on in the development cycle. Using the aforementioned methods, staying on the same page and keeping coordinated went exactly as planned.

Work/ Person	Joshua	Baron	Nelson
Hardware: Battery	Primary	S	S
Hardware: Casing	S	S	S
Hardware: PCB design	S	Primary	S
Hardware: Electronics	Primary	S	S
Software: Programming	S	S	Primary
LED Programming	S	Primary	S
Materials Management	S	S	Primary

Figure 8-3 Division of Labor

9. Project Summary and Conclusions

After working through the research and design process for Essence of Music, the Essence of Music team has come to many conclusions and has extended our understanding into standardized engineering practices. Primarily, working towards completing the project has furthered knowledge in the area of hardware especially for our Computer Engineers who have previously had much more extensive study and practice in the software world. Essence of Music helped put into practice a lot of theory that has been described in the classroom especially in the aspects of circuit design. For a long time now, we could all do simple Kirchoff's Voltage Law and understand the theory behind how microcontrollers functioned, but creating a full-fledged project has enlightened us in how much work and what aspects of the design process have to be taken into account. Knowing how to calculate frequency responses, for example, does not necessarily mean an engineer understands how to make a useful product that a user desires and is willing to invest in. The classroom for undergraduate programs does not often in enough display the economic aspect of the design process and creating this project has significantly improved our holistic awareness.

Essence of Music incorporates power systems, microcontrollers and practical design characteristics. Understanding the theory behind these mechanisms has significantly enhanced the output of the project. This brings us to the conclusion that Essence of Music is a good product with standard engineering practices that shows how the arts and sciences have a lot of crossover.

Appendices

Appendix A - Copyright Permissions

According to TI website:

Subject to any Service Terms that may apply, TI grants you permission to download, reproduce, display, and distribute TI Services solely for non-commercial or personal use, provided that you do not modify such TI Services, and provided further that you retain all copyright and proprietary notices as they appear in such TI Services.

<http://www.ti.com/corp/docs/legal/termsfuse.shtml>

Appendix B - References

[1] Andrew Jones. (2015, Jan 10). Cheap 18650 Lithium Ion Batteries to Create the Ultimate 192V 4000W Electric Go-Cart or Car: Series [Video file]. Retrieved from <https://www.youtube.com/watch?v=qc7UlvS-Q-So>

[2] ASCAS. (n.d.). DIY Bluetooth Speaker. Retrieved from [instructables.com](http://www.instructables.com/id/DIY-Bluetooth-Speaker-PartyBar/): <http://www.instructables.com/id/DIY-Bluetooth-Speaker-PartyBar/>

[3] Make:. (2013, Aug 23). Weekend Projects - Android-Arduino LED Strip Lights [Video file]. Retrieved from <https://www.youtube.com/watch?v=Hn9KfJQWqgl>

[4] TinselKoala. (2013, Dec 30). Arduino: LED Twinkler: Basic Analog Input, Digital Output, PWM [Video file]. Retrieved from <https://www.youtube.com/watch?v=cUvcnl3f7ec>

[5] Make:. (2014, Mar 27). DIY Hacks & How To's: TV Remote Controlled Electronics [Video file]. Retrieved from <https://www.youtube.com/watch?v=tvRLz4RL0eo>

[6] Smith, S. W. (n.d.). *The Scientist and Engineer's Guide to Digital Signal Processing*. Retrieved from [dspguide.com](http://www.dspguide.com): <http://www.dspguide.com/ch21/1.html>

[7] Connor Wilson. (2012, Jan 12). Power Your Rig, Build a 12v Battery Pack for \$20! [Video file]. Retrieved from <https://www.youtube.com/watch?v=ak3QtX0zFAg>

[8] EEVblog. (2011, Jun 8). EEVblog #176 - Lithium Ion/Polymer Battery Charging Tutorial [Video file]. Retrieved from https://www.youtube.com/watch?v=A6mKd5_-abk

- [9] Keysight EEsof EDA. (2015, Aug 25). How to Design DC-to-DC Converters [Video file]. Retrieved from <https://www.youtube.com/watch?v=LwPJi3jfw0>
- [10] Menting, D. (n.d.). *RGB LED strips: an overview*. Retrieved from nut-bolt.nl: <http://nut-bolt.nl/2012/rgb-led-strips/>
- [11] Prototyping Software to Make Things Easy. (n.d.). Retrieved from energia.nu: <http://energia.nu/>
- [12] (n.d.). Retrieved from amazon.com: <http://www.amazon.com/ATMEGA328P-PU-with-Arduino-Bootloader-Uno/dp/B007SH0D0A>
- [13] ATmega48A/PA/88A/PA/168A/PA/328/P. (n.d.). Retrieved from atmel.com/images: http://www.atmel.com/images/atmel-8271-8-bit-avr-microcontroller-atmega48a-48pa-88a-88pa-168a-168pa-328-328p_datasheet_complete.pdf
- [14] Caldwell, J. (n.d.). *Analog, Active Crossover Circuit for Two-Way*. Retrieved from ti.com: <http://www.ti.com/lit/ug/tidu035/tidu035.pdf>
- [15] IDC: Smartphone OS Market Share. (n.d.). Retrieved December 3, 2015, from <http://www.idc.com/prodserv/smartphone-os-market-share.jsp>
- [16] Bluetooth 4.2 is here – but what does it mean? - CSR. (2014, December 15). Retrieved from <http://blog.csr.com/2014/12/bluetooth-4-2-is-here-but-what-does-it-mean/>
- [17] I want to develop Android Apps - What languages should I learn? (2014, June 10). from <http://www.androidauthority.com/want-develop-android-apps-languages-learn-391008/>
- [18] Noise-Induced Hearing Loss. (n.d.). Retrieved from <http://www.nidcd.nih.gov/health/hearing/pages/noise.aspx>
- [19] Title IV - Noise Pollution. (n.d.). Retrieved from <http://www.epa.gov/clean-air-act-overview/title-iv-noise-pollution>

[20] Are Bright Lights Damaging to the Eye? (2015, May 26). Retrieved from <http://www.brightfocus.org/macular/article/are-bright-lights-damaging-eye>

[21] Ensuring safety in LED lighting | Electronics Weekly. (2012, November 8). Retrieved from <http://www.electronicweekly.com/news/products/led/ensuring-safety-in-led-lighting-2012-11/>

[22] JavaScript Style Guide and Coding Conventions. (n.d.). Retrieved from http://www.w3schools.com/js/js_conventions.asp

[23] Kane, M. (n.d.). 18650 Lithium-Ion Battery Cell Fuse Test – Video. Retrieved from [insideevs.com: http://insideevs.com/18650-lithium-ion-battery-cell-fuse-test-video/](http://insideevs.com/18650-lithium-ion-battery-cell-fuse-test-video/)

[24] (n.d.). Retrieved from [harborfreight.com: http://www.harborfreight.com/5-piece-heat-shrink-wire-wrap-assortment-9639.html](http://www.harborfreight.com/5-piece-heat-shrink-wire-wrap-assortment-9639.html)

[25] Decibel (Loudness) Comparison Chart. (n.d.). from <http://www.gcaudio.com/resources/howtos/loudness.html>

[26] (n.d.). Retrieved from [thomann.de: http://www.thomann.de/gb/adam_hall_4903tp_gummifuss.htm](http://www.thomann.de/gb/adam_hall_4903tp_gummifuss.htm)

[27] (n.d.). Retrieved from [industrial.panasonic.com: http://industrial.panasonic.com/lecs/www-data/pdf2/ACA4000/ACA4000CE240.pdf](http://industrial.panasonic.com/lecs/www-data/pdf2/ACA4000/ACA4000CE240.pdf)

[28] NanJing Top Power ASIC Corp. 1A Standalone Linear Li-Ion Battery Charger with Thermal Regulation in SOP-8. Retrieved from <https://dlnmh9ip6v2uc.cloudfront.net/datasheets/Prototyping/TP4056.pdf>

[29] Arduino - PinMapping168. (n.d.). from <https://www.arduino.cc/en/Hacking/PinMapping168>

Appendix C - Code

```
#include <avr/wdt.h>
#include <avr/pgmspace.h>
#include <Adafruit_GFX.h> // Core graphics library
#include <RGBmatrixPanel.h> // Hardware-specific library
```

```

//Global Static Variables
#define CLK 8 // MUST be on PORTB!
#define LAT A3
#define OE 9
#define A A0
#define B A1
#define C A2
#define analogInput A5

//unsigned char fht_log_out[FHT_N/2];

//void fillCol(int row, int columns);

//Global Variable
int newInput = 0; //Reads the value of the incoming signal.

const int profButton = 10;
const int colorButton = 11;
int profButtonVal = 0;
int colorButtonVal = 0;
int profButtonDelay = 10;
int colorButtonDelay = 10;
int prof = 0;
int cScheme = 0;

int counter = 0;
RGBmatrixPanel matrix(A, B, C, CLK, LAT, OE, true);
//Basic Setup for programming
void setup(){

    matrix.begin();
    Serial.begin(115200);
    //randomSeed(analogRead(A5));
    pinMode(profButton, INPUT);
    pinMode(colorButton, INPUT);

}

void loop(){

    if(prof == 0) profile1();
    else if(prof == 1) profile2();

```

```

else if(prof == 2) profile3();

//Serial.println(analogRead(analogInput));
//Serial.println(prof);
//Serial.println(buttonDelay);

if(profButtonVal == 1){
  if(profButtonDelay <= 0){prof++; profButtonDelay = 10; cScheme = 0;}
  profButtonVal = 0;}
if(prof >= 3) prof = 0;
//profileA();
if(profButtonDelay >= 0) profButtonDelay--;

if(colorButtonVal == 1){
  if(colorButtonDelay <= 0){cScheme++; colorButtonDelay = 10;}
  colorButtonVal = 0;}
if(cScheme >= 6) cScheme = 0;
//profileA();
if(colorButtonDelay >= 0) colorButtonDelay--;

}

void profile1(){

  matrix.fillScreen(0);
  int inputMatrix[32] = {0,0,0,0,0,0,0,0,0,0,0,0,0,0,0,0,0,0,0,0,0,0,0,0,0,0,0,0,0,0,0,0};
  //matrix.drawPixel(counter, 8, matrix.Color333(0, 0, 7));
  //matrix.drawPixel(8, counter/2, matrix.Color333(7, 0, 0));
  int Red1, Red2, Green1, Green2, Blue1, Blue2;

  if(cScheme == 0){
    Red1=4;
    Green1=0;
    Blue1=4;
    Red2=0;
    Green2=4;
    Blue2=4;
  }
  else if(cScheme == 1){
    Red1=4;
    Green1=0;
    Blue1=0;
    Red2=0;
    Green2=4;
  }
}

```

```

    Blue2=0;
}
else if(cScheme == 2){
    Red1=4;
    Green1=4;
    Blue1=0;
    Red2=0;
    Green2=0;
    Blue2=4;
}
else if(cScheme == 3){
    Red1=3;
    Green1=0;
    Blue1=5;
    Red2=0;
    Green2=4;
    Blue2=0;
}
else if(cScheme == 4){
    Red1=7;
    Green1=0;
    Blue1=2;
    Red2=4;
    Green2=4;
    Blue2=0;
}
else if(cScheme == 5){
    Red1=0;
    Green1=4;
    Blue1=0;
    Red2=0;
    Green2=0;
    Blue2=4;
}

for(int i = 0; i < 32; i++){
    inputMatrix[i] = analogRead(analogInput)/64;
    //matrix.drawPixel(i, inputMatrix[i], matrix.Color333(random(7), random(7),
random(7)));
    //matrix.drawPixel(31 - i, inputMatrix[i], matrix.Color333(random(7), random(7),
random(7)));
    matrix.drawPixel(i, inputMatrix[i], matrix.Color333(Red1, Green1, Blue1));
    matrix.drawPixel(31 - i, inputMatrix[i], matrix.Color333(Red2, Green2, Blue2));
    matrix.swapBuffers(true);
}

```

```

    if (digitalRead(profButton) == HIGH) profButtonVal = 1;
    if (digitalRead(colorButton) == HIGH) colorButtonVal = 1;
}

}

void profile2(){

matrix.fillScreen(0);
int columns[32] = {0,0,0,0,0,0,0,0,0,0,0,0,0,0,0,0,0,0,0,0,0,0,0,0,0,0,0,0,0,0,0,0};
for(int i = 0; i < 32; i++) columns[i] = analogRead(analogInput)/64;
for(int i = 0; i < 2; i++){
    fillCol(i, columns[i]);
    fillCol(i+8, columns[i+8]);
    fillCol(i+16, columns[i+16]);
    fillCol(i+24, columns[i+24]);
    fillCol(i+4, columns[i+4]);
    fillCol(i+12, columns[i+12]);
    fillCol(i+20, columns[i+20]);
    fillCol(i+28, columns[i+28]);
    fillCol(i+2, columns[i]);
    fillCol(i+6, columns[i+6]);
    fillCol(i+10, columns[i+10]);
    fillCol(i+14, columns[i+14]);
    fillCol(i+18, columns[i+18]);
    fillCol(i+22, columns[i+22]);
    fillCol(i+26, columns[i+26]);
    fillCol(i+30, columns[i+30]);

matrix.swapBuffers(true);
delay(.01);
if (digitalRead(profButton) == HIGH) profButtonVal = 1;
if (digitalRead(colorButton) == HIGH) colorButtonVal = 1;

}

}

void profile3(){
for(int i = 0; i < 10; i++){
    int data = analogRead(A5);
    if(data > 750)matrix.fillScreen(matrix.Color333(random(8), random(8), random(8)));
    matrix.swapBuffers(true);
    if (digitalRead(profButton) == HIGH) profButtonVal = 1;
}
}

```

```
}  
void profileA(){  
    for(int i = 0; i < 50; i++) profile1();  
    for(int i = 0; i < 50; i++) profile2();  
    matrix.Color333(random(8), random(8), random(8));  
    matrix.swapBuffers(true);  
    for(int i = 0; i < 50; i++) profile3();  
}  
void fillCol(int row, int columns){  
    int Red1, Red2, Red3, Green1, Green2, Green3, Blue1, Blue2, Blue3;  
  
    if(cScheme == 0){  
        Red1=0;  
        Green1=0;  
        Blue1=7;  
        Red2=7;  
        Green2=7;  
        Blue2=7;  
        Red3=7;  
        Green3=0;  
        Blue3=0;  
    }  
    else if(cScheme == 1){  
        Red1=0;  
        Green1=4;  
        Blue1=0;  
        Red2=0;  
        Green2=0;  
        Blue2=4;  
        Red3=3;  
        Green3=0;  
        Blue3=5;  
    }  
    else if(cScheme == 2){  
        Red1=4;  
        Green1=0;  
        Blue1=0;  
        Red2=7;  
        Green2=1;  
        Blue2=0;  
        Red3=4;  
        Green3=4;  
        Blue3=0;  
    }  
}
```

```

}
else if(cScheme == 3){
    Red1=7;
    Green1=0;
    Blue1=2;
    Red2=0;
    Green2=4;
    Blue2=4;
    Red3=7;
    Green3=1;
    Blue3=0;
}
else if(cScheme == 4){
    Red1=7;
    Green1=0;
    Blue1=2;
    Red2=7;
    Green2=0;
    Blue2=2;
    Red3=7;
    Green3=0;
    Blue3=2;
}
else if(cScheme == 5){
    Red1=0;
    Green1=4;
    Blue1=4;
    Red2=0;
    Green2=4;
    Blue2=4;
    Red3=0;
    Green3=4;
    Blue3=4;
}
for(int i = 0; i < columns; i++){
    if(i < 6)
        matrix.drawPixel(row, 16 - i, matrix.Color333(Red1, Green1, Blue1));
    else if(i < 11)
        matrix.drawPixel(row, 16 - i, matrix.Color333(Red2, Green2, Blue2));
    else
        matrix.drawPixel(row, 16 - i, matrix.Color333(Red3, Green3, Blue3));
    //matrix.drawPixel(row, 16 - i, matrix.Color333(random(7), random(7), random(7)));
}
}
}

```